

POWERHORSE™

Owner's Manual

M115177

ITEM NUMBER: 115177

SERIAL NUMBER: _____

2.6 GPM, 3600 PSI Pressure Washer — EPA Compliant

Instructions for Installation/Set-up, Operation, Maintenance, & storage

This pressure washer produces hot-water high-pressure spray. Cleaning chemicals may be incorporated into the spray if desired. The pressure pump for this equipment is powered by a gasoline internal combustion engine.

WARNING: SPECIAL HAZARDS

- **CO Poisoning:** Exhaust from engine contains carbon monoxide, a poisonous gas that can cause carbon monoxide poisoning and possible death if inhaled.
 - **Injection Injury:** High-pressure spray can pierce skin and underlying tissues, leading to serious injury and possible amputation. Such an injection injury can result in blood poisoning and/or severe tissue damage.
 - **Flying Debris:** High-pressure spray can cause flying debris and possible surface damage.
 - **Electric shock:** Operating equipment in wet conditions or near water can cause electric shock.
 - **Chemical Exposure:** Cleaning chemical vapors or contact with skin may be hazardous.
 - **Fire/Explosion:** Engine sparking can ignite fuel or other flammable liquids or vapors in the vicinity. Hot exhaust from engine can ignite combustible materials. Always keep a fire extinguisher rated "ABC" nearby.
 - **Burns:** Pressure Washer pump and engine are hot surfaces that can cause burn injuries.
- Detailed safety information about these hazards appears throughout this manual.

Equipment Protection Quick Facts

Inspect Upon Delivery: FIRST! Inspect for missing or damaged components. See "Initial Set-Up/Installation" section for where to report missing or damaged parts.

Add Engine Oil: Engine is shipped **without oil**. See the "Engine Manual" section of this manual for instructions on capacity and viscosity recommendations.

Water Flow Requirements: Make sure your supply water flow rate is 20% higher than the pressure washer's flow rate (see "Operations", section for detail), and that your water is clean and particle free.

Chemical Spraying: Use only approved pressure washer chemicals designed for high-pressure use.

Storage: Do not allow water to freeze in the pump, hose, or spray gun(s). See "Storage" for more information.

Maintenance Schedule: Engine and pump require periodic inspection and servicing to keep pressure washer functioning efficiently. See "Maintenance Schedule Summary" for frequency of servicing.

Any Questions, Comments, Problems, or Parts Orders
Call Powerhorse Product Support 1-866-443-2576

Table of Contents

Equipment Protection Quick Facts.....	1
TABLE OF CONTENTS	2
ABOUT YOUR PRESSURE WASHER	4
SPECIFICATIONS	5
COMPONENT IDENTIFICATION	6
SAFETY	8
Hazard Signal Word Definitions.....	8
ON PRODUCT LABELS	9
Decal Locations.....	9
Decals	10
INITIAL SET-UP	13
Step 1. Inspect & Unpack	13
OPERATION	17
Safety Rules for Operation.....	17
Preparing for Operation.....	18
Check/Add Engine Oil	18
Inspect Fuel System/Check for Leaks.....	20
Connect Hoses, Water Supply, and Spray Nozzle	20
Prime the Water Supply.....	22
Set Up for Chemical Spray (if desired).....	22
Gas system ready (if hot water cleaning is required).....	23
Apply Cleaning Chemical (If Desired).....	23
Pump Components	23
Water heater components.....	23
Start-Up Procedures	24
Begin High Pressure Spray	24
Shutdown.....	25
STORAGE	26
Between-Use Storage	26
Prepare Pressure Washer for Freezing Conditions	26
Prepare Engine for Long Term Storage	27
Prepare Pressure Washer for Storage	27
MAINTENANCE & REPAIR	28
MAINTENANCE SCHEDULE SUMMARY	28
DETAILED INSTRUCTIONS – MAINTENANCE & REPAIR	28
Follow Safety Rules.....	28
Keep Pressure Washer Clean.....	28
Inspect Spray System	29
Do not start pressure washer until all needed repairs have been completed	29
TROUBLESHOOTING	31
PARTS EXPLOSION- MODEL 115177 – REV A.1	32

PARTS LIST - MODEL 115177 – REV A.1.....	33
PUMP EXPLOSION	34
PUMP PARTS LIST	35
PUMP KIT PARTS LIST	36
ENGINE EXPLOSION	37
ENGINE PARTS LIST	38
ENGINE KIT LIST	39
ENGINE MANUAL	40
ENGINE STARTING COMPONENTS.....	40
MAINTENANCE SCHEDULE	41
ENGINE OIL RECOMMENDATIONS	41
LIMITED WARRANTY	45

About Your Pressure Washer

Thank you for purchasing a Powerhorse Pressure Washer! It is designed for long life, dependability, and top performance.

Intended Use. Produce a high-pressure water spray. Provide a high-pressure water on 149°F at most. Incorporate cleaning chemicals into a low-pressure water spray.

Note: Do not use for other purposes, as unforeseen hazards or equipment damage may result.

Power Source. The pressure washer is powered by a gasoline engine.

Supplies Required. Normal operation will require you to supply:

- Gasoline
- Engine oil
- Personal Protection Equipment

See “*Specifications*” section of this manual for more detail.

Site Location. Intended for outdoor use only.

Personal Protection. Wear safety apparel during operation, including safety glasses with side and top protection. Ear protection is also recommended if working near any operating engine. Other safety apparel includes waterproof insulated gloves, and non-slip protective footwear. Cleaning chemicals may require the use of respiration mask; refer to chemical label for further instruction.

Adult control only. Only trained adults should set up and operate the pressure washer. Do not let children operate.

Under The Influence. Never operate, or let anyone else operate, the pressure washer while fatigued or under the influence of alcohol, drugs, or medication.

Keep this manual for reference and review.

ATTENTION: Rental Companies and Private Owners who loan this equipment to others!

All persons to whom you rent/loan this pressure washer to must have access to and read this manual. Keep this owner's manual with the pressure washer at all times and advise all persons who will operate the machine to read it. You must also provide personal instruction on how to safely set-up and operate the pressure washer and remain available to answer any questions a renter/borrower might have. Owner's Manuals are available from Powerhorse at 1-866-443-2576

Specifications

Model #	115177
FLOW OUTPUT	
PSI (bar)	3600 (248.3)
GPM (l/min)	2.6 (9.84)
Max Water Temp	149°F (65°C)
ENGINE	
Engine	Powerhorse
Horsepower	212CC
DIMENSIONS / COMPONENTS	
Length	37"
Width	22.2"
Height	38.8"
Weight	168lbs
SUPPLIES REQUIRED (not included)	
Engine Oil	Refer to the "Engine Manual" section

Component Identification

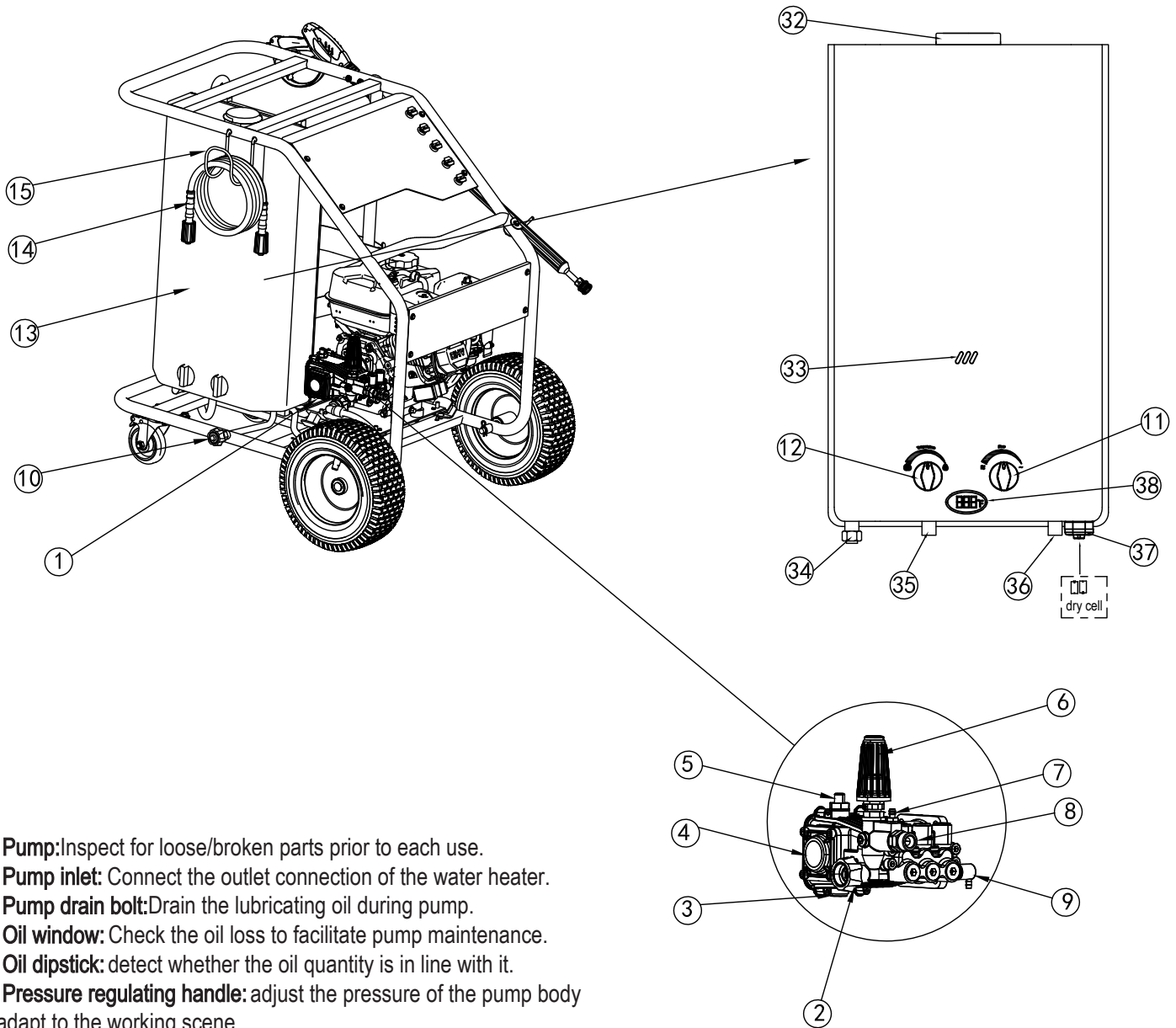

1. **Pump:** Inspect for loose/broken parts prior to each use.
2. **Pump inlet:** Connect the outlet connection of the water heater.
3. **Pump drain bolt:** Drain the lubricating oil during pump.
4. **Oil window:** Check the oil loss to facilitate pump maintenance.
5. **Oil dipstick:** detect whether the oil quantity is in line with it.
6. **Pressure regulating handle:** adjust the pressure of the pump body to adapt to the working scene.
7. **Aspiration nozzle:** Push chemical hose onto injector to route chemical into pump.
8. **Pump outlet:** Connect high pressure hose here.
9. **Thermostat valves:** Valve that regulates water temp in the pump.
10. **Water inlet connectors:** Attach garden hose here.
11. **Water inlet control knob:** adjust the amount of water inlet.
12. **Gas control knob:** adjust the gas intake, control combustion, and adjust water temperature.
13. **Water heater:** Inspect for loose/broken parts prior to each use.
14. **High pressure hose:** Attach couplers to gun and water outlet.
15. **High-pressure hose hook:** Holds high-pressure hose.

32. **Smoke exhaust port:** LPG combustion exhaust gas is discharged, do not touch it at high temperature.
33. **Fire Observation Hole:** Observe the gas condition
34. **Water Heater Outlet Connector:** The inlet connector that connects the pump
35. **Water Heater Inlet Connector:** Connects the gas pipe asse
36. **Water heater inlet connector:** Attach garden hose here.
37. **Battery box:** In all 2 x D(1.5V) No. 1 dry batteries
38. **Temperature Indicator:** Check the temperature of the water being sprayed

See "Parts Explosion" for more details

Component Identification

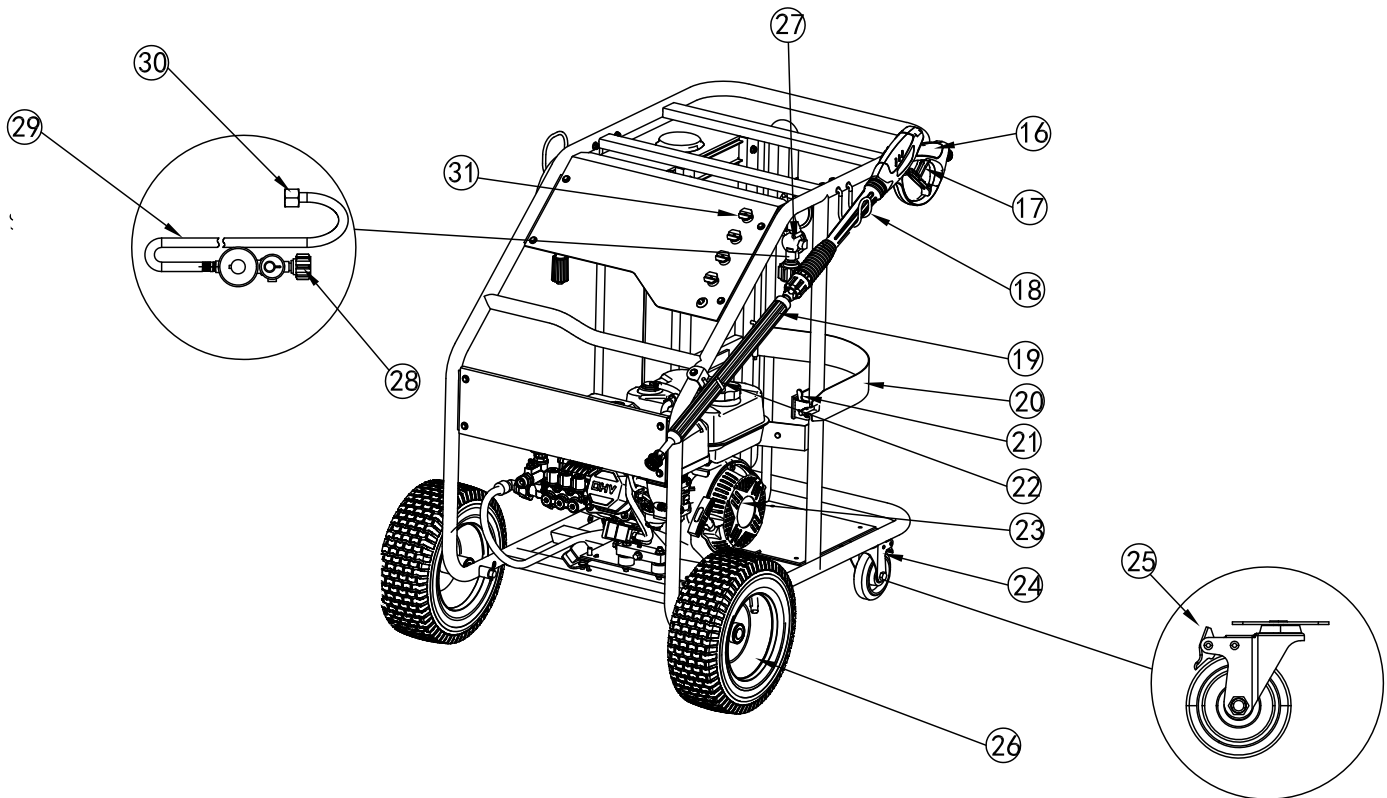

- 16. **Spray gun:** connect the high-pressure hose and lance.
- 17. **Trigger:** Pull to allow pressurized water to flow out of spray gun.
- 18. **Upper stock:** stores the spray gun.
- 19. **Lance:** connects the spray gun and the nozzle.
- 20. **Gas tank fixing plate:** protect the gas tank from being damaged.
- 21. **Lock:** fix the LPG gas tank and protect the gas tank from toppling.
- 22. **Lower butt:** stores the lance.
- 23. **Engine:** The air-cooled engine powers the pump.
- 24. **Universal wheel:** support frame; orientation adjustments can be made as the rack moves.
- 25. **Universal wheel brake:** Fix the frame without moving.
- 26. **Inflatable wheels:** support the frame.
- 27. **Pressure Reducing Valve:** Adjusts the pressure of the gas entering the water heater.
- 28. **Pressure Reducing Valve Joint:** Connected to the LPG gas tank.
- 29. **Tracheal assembly:** connect the LPG gas tank and water heater, and adjust the pressure of the LPG.
- 30. **Pressure Reducing Valve Connector:** Connect to the water heater.
- 31. **Nozzle:** Change nozzles for different spray patterns.

Safety

Hazard Signal Word Definitions



This is the safety alert symbol. It is used to alert you to potential personal injury hazards. Obey all safety messages that follow this symbol to avoid possible injury or death.

DANGER (red) indicates a hazardous situation, which if not avoided, will result in death or serious injury.

WARNING (orange) indicates a hazardous situation, which if not avoided, could result in death or serious injury.

CAUTION (yellow), used with the safety alert symbol, indicates a hazardous situation, which if not avoided, could result in minor or moderate injury.

CAUTION (yellow), without the safety alert symbol, is used to address practices not related to personal injury.

NOTICE is used to address practices not related to personal injury.

On Product Labels

Decal Locations

⚠ WARNING:

ALWAYS make sure safety labels are in place and in good condition. If a safety label is missing or not legible, order new labels from Powerhorse Product Support at 1-866-443-2576

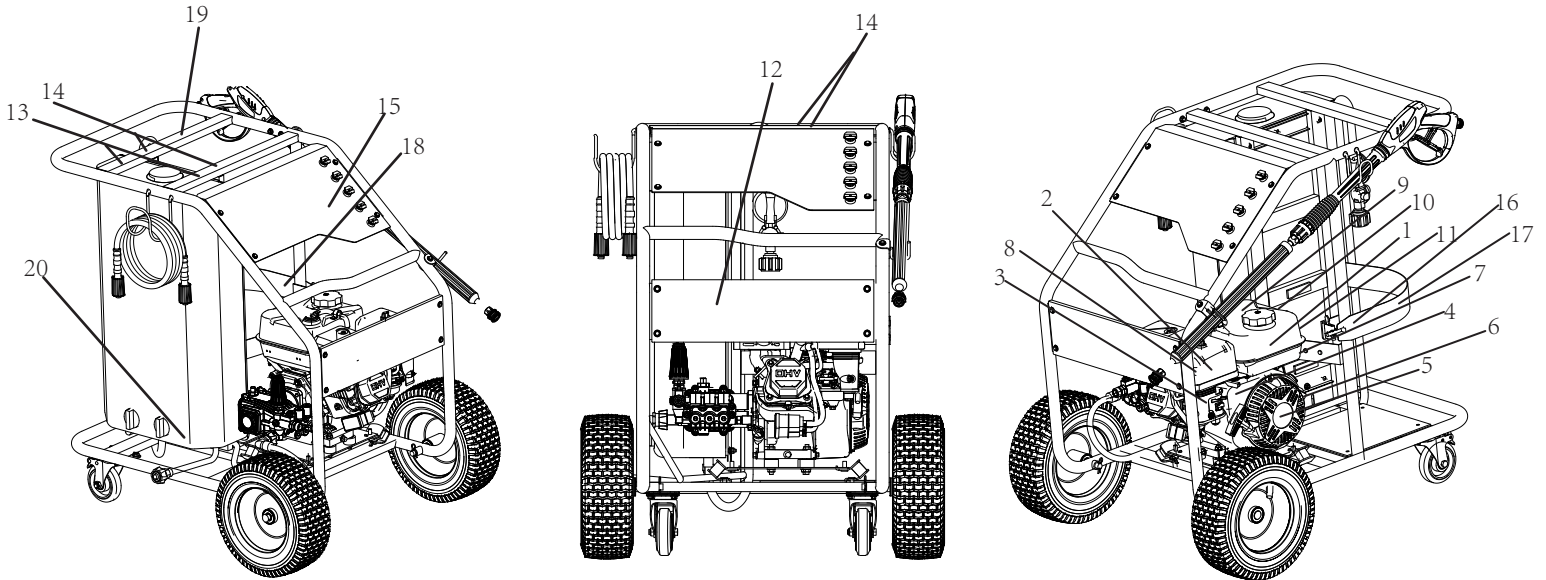

On-Product Warning Labels		
Location	Part Number	Description
1	PH115177.D1	Brand
2	PH115177.D2	Air filter
3	PH115177.D3	Throttle damper
4	PH115177.D4	Throttle
5	PH115177.D5	Recoil
6	N/A	Emissions
7	PH115177.D7	Prop65
8	PH115177.D8	E85
9	PH115177.D9	High Temperature Warning
10	PH115177.D10	Poisonous Gas Warning
11	PH115177.D11	Fuel Fire Explosion Hazard Warning
12	PH115177.D12	Operating Instructions
13	PH115177.D13	Anti-scald Warning
14	PH115177.D14	Anti-virus Warning
15	PH115177.D15	Nozzle
16	PH115177.D16	Warning
17	PH115177.D17	High-Pressure Hose Warning
18	PH115177.D18	Parameter
19	PH115177.D19	Pressure Reducing Valve
20	PH115177.D20	Battery

Decals

1



6

EMISSION CONTROL INFORMATION

NORTHERN TOOL + EQUIPMENT POWER HORSE

NORTHERN TOOL & EQUIPMENT COMPANY, INC.
 THIS ENGINE IS CERTIFIED TO OPERATE ON UNLEADED GASOLINE
 THIS ENGINE MEETS U.S. EPA EXH AND EVAP REGS FOR [2023]
 EXH ENGINE FAMILY: PC DPS 224 1D J
 EVAPORATIVE FAMILY: PC D P P N H E Q 002
 DISPLACEMENT: 212CC
 LUBRICANT REQUIREMENTS: API SERVICE CATEGORY SF
 EXHAUST EMISSION CONTROL: EM
 EMISSION COMPLIANCE PERIOD: 125 HOURS

2023 J F M A M J J A S O N D
 A A A A A M J J A S O N D

2



7

CALIFORNIA PROPOSITION 65

WARNING: This product can expose you to chemicals including Lead, which is known to the State of California to cause cancer and birth defects or other reproductive harm. For more information, visit www.P65warnings.ca.gov.

PROPOSITION 65 DE L'ÉTAT DE CALIFORNIE

AVERTISSEMENT : Ce produit peut vous exposer à des produits chimiques (le plomb, entre autres) reconnus par l'État de la Californie comme pouvant causer des cancers ou des malformations congénitales et autres effets nuisibles sur la reproduction. Pour de plus amples renseignements, consultez le www.P65Warnings.ca.gov.

CALIFORNIA - PROPUESTA DE LEY NÚM. 65

ADVERTENCIA : Este producto por su uso pueden contener sustancias químicas (incluido el plomo) reconocidas por el estado de California como causantes de cáncer, defectos congénitos y otras afecciones del aparato reproductor. Para más información visite www.P65Warnings.ca.gov.

3



8

CAUTION

E0 E10 E15 E85

ETHANOL FREE

DO NOT USE FUEL CONTAINING MORE THAN 10% ETHANOL; IT IS A VIOLATION OF U.S. FEDERAL LAW, WILL DAMAGE YOUR PRODUCT AND VOID THE WARRANTY.

4



9

WARNING

Burn Hazard

Do not touch hot muffler. Muffler may be hot even if the unit is stopped.

Allow unit to cool before servicing.

5



10

WARNING

Poisonous Gas



This product gives off carbon monoxide, a poisonous gas that can kill you. You CANNOT smell it, see it, or taste it.

- ONLY use outside & far away from windows, doors, & vents.
- NEVER use inside homes, garages, or sheds, EVEN if you run a fan or open doors or windows. See owner's manual for more details.

To order replacement safety labels, call Powerhorse Product Support at 1-866-443-2576

Decals Continued

11

	⚠ WARNING Fuel Fire/Explosion Hazard Fuel is flammable and explosive.
	Never fuel a running or hot engine. Clean up fuel spills immediately. Ensure there are no fuel leaks before starting.
	Keep sources of sparks and flames away. Hot exhaust may also ignite spilled fuel. No Smoking. Keep a fire extinguisher nearby.

15



POWERHORSE™

3600 PSI 2.6 GPM

15° NOZZLE
25° NOZZLE
40° NOZZLE
CHEMICAL NOZZLE
SPARE

12

	OPERATING INSTRUCTIONS		
	STARTUP		SHUTDOWN
	<ol style="list-style-type: none"> 1. Connect LPG hose. 2. Attach garden hose. 3. Connect hose from water heater to pump. 4. Attach pressure hose. 5. Attach gun and lance. 6. Turn water supply ON. 	<ol style="list-style-type: none"> 7. Insert nozzle. 8. Squeeze trigger to purge air from pump. 9. Open LPG valve. 10. Start engine. 11. Adjust water temperature and flow per demands. 	<ol style="list-style-type: none"> 1. Close LPG valve. 2. Turn engine OFF. 3. Turn water supply OFF. 4. Squeeze trigger to relieve system pressure. 5. Remove garden hose. 6. Remove pressure hose.

13

⚠ WARNING	
	Burn Hazard

14

⚠ DANGER	
NEVER use inside a home or garage. EVEN IF doors and windows are open.	Only use OUTSIDE and far away from windows, doors, and vents.

To order replacement safety labels, call Powerhorse Product Support at 1-866-443-2576

Decals

16

⚠ WARNING

Secure the bezel buckle before use





19



LPG CONNECTION

17

⚠ WARNING

-  1.) **Skin puncture hazard.** Do not direct spray at people or animals. Seek IMMEDIATE surgical treatment.
-  2.) **Risk of fire and explosion.** Do not add fuel when engine is running or still hot.
-  3.) **Breathing hazard.** Poisonous fumes from engine can kill you. Do not operate indoors even if ventilated.
-  4.) **Risk of electrocution.** Keep water away from electric outlets and electric devices.
-  5.) **Read owner's manual.** Serious injury or death can result if safety instructions are not followed.

20

CAUTION

 battery installation

Install batteries before using the water heater.

18

POWERHORSE

ITEM# 115177

S/N:

PRODUCT TYPE: **PRESSURE WASHER GASOLINE DRIVEN**

PUMP OIL: **SAE85W-90 Gear Oil**

MAX. VOLUME	MAX. PRESSURE	MAX. WATER TEMP
2.6GPM	3600PSI	149°F

USE UNLEADED GASOLINE AND 10W30 ENGINE OIL
USE ONLY CLEANING FLUIDS RECOMMENDED FOR PRESSURE WASHERS

FOR OUTDOOR USE ONLY - STORE INDOORS

MAX RATINGS DETERMINED BY PWMA STANDARD 101

⚠ WARNING: This product contains chemicals known to the State of California to cause cancer, birth defects or other reproductive harm.
Wash hands after handling.

Distributed by Northern Tool & Equipment Company, Inc.
Burnsville, MN 55306 | NorthernTool.com | Made in Vietnam

To order replacement safety labels, call Powerhorse Product Support at 1-866-443-2576





Initial Set-Up

Step 1. Inspect & Unpack

Upon receiving your item check for missing or damaged parts.

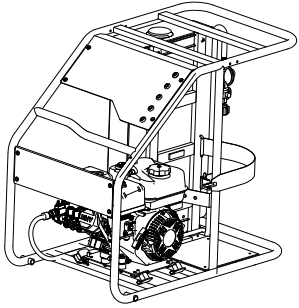
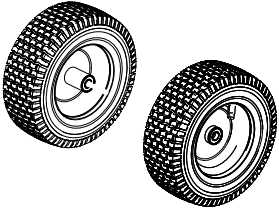
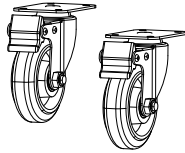
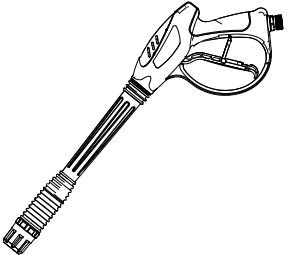
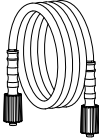
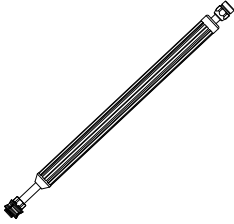
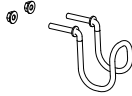
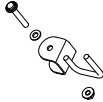
See “*Component Identification*” section of this manual for a diagram of the pressure washer and its components.

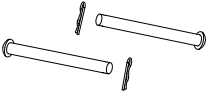
- For missing or damaged components, please contact Product Support at 1-866-443-2576.
- If complete, fill out product serial number information. See “*Limited Warranty*” section of this manual.

 <p>Engine/Pump</p>	 <p>Wheels</p>	 <p>Wheels</p>
 <p>Spray Gun</p>	 <p>Pressure Hose</p>	 <p>Lance</p>
 <p>Upper Gun Hook</p>	 <p>Lower Gun Hook & M6 Screw + Nut + Washer</p>	 <p>Hose Handle</p>
 <p>Axles & pin</p>	 <p>Nozzle</p>	 <p>Chemical Hose</p>

Step 2. Assembly

Note: Remove contents from box and assembly can occur at this time.

Wheel to Base Assembly

1. Install wheels on the pressure washer base using:

- (2) Axles
- (2) Hair Pins

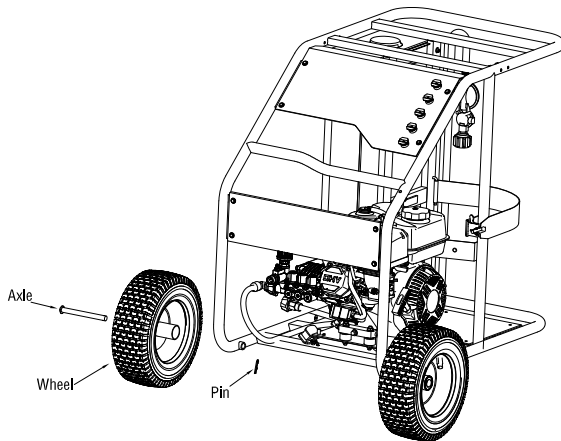

Repeat the process as pictured to install the wheel on opposite side.

Check that wheels turn freely.

Universal wheel to Base Assembly

2. Attach Universal wheel the pressure washer base using:

- (8) M8 screw

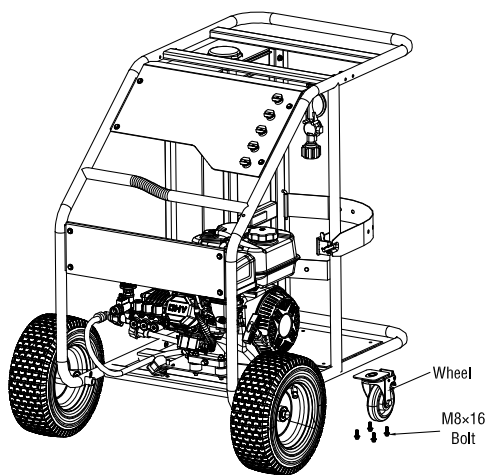

After completing this step the pressure washer cart assembly may now be placed right side up, ensuring that the wheels and leg are on a flat surface.

Gun Hook Assembly

3. Attach upper gun hook on the pressure washer

- ☒ (2) M6 lock nuts

Attach lower gun hook on the pressure washer :

- (1) M6 x 45 bolt
- (1) Flat washer
- (1) M6 lock nut

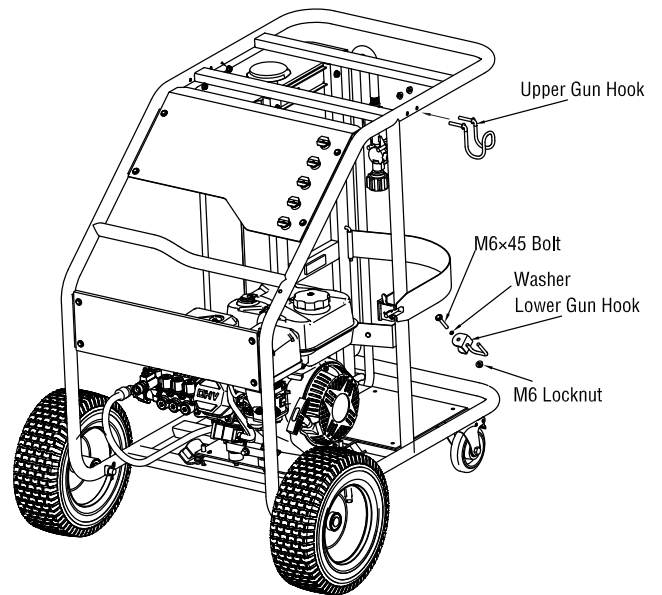

Hose Holder Hook

5. Attach the hose holder hook to the pressure washer :

- (2) M6 lock nuts

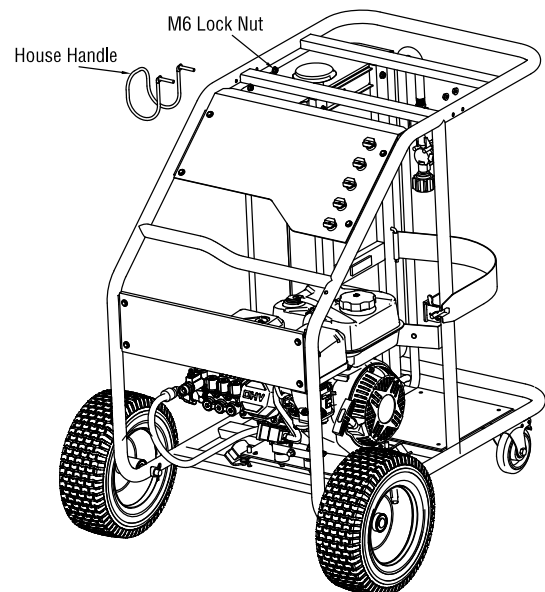

Wheel Assembly Instruction

Step 1 Open the carton

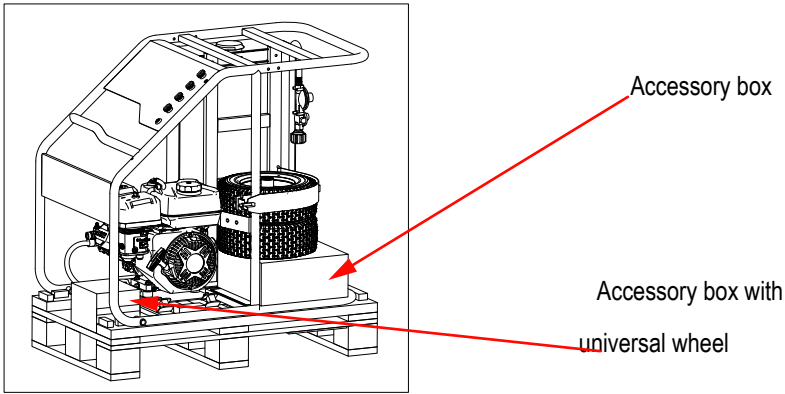

Step 2 Take out wheels, axles and R pins from the accessory box

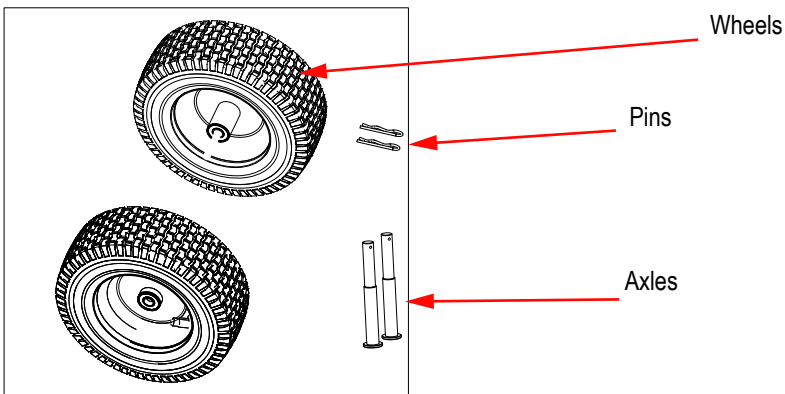

Step 3 Keep the whole unit on the pallet and install wheels

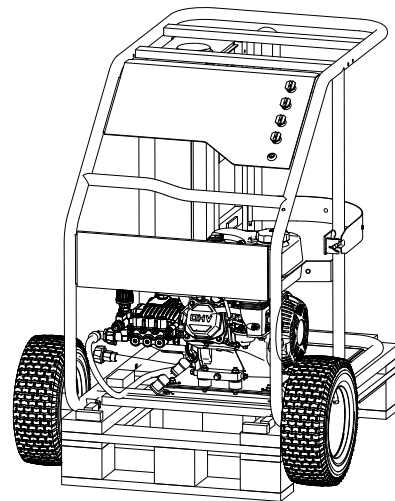
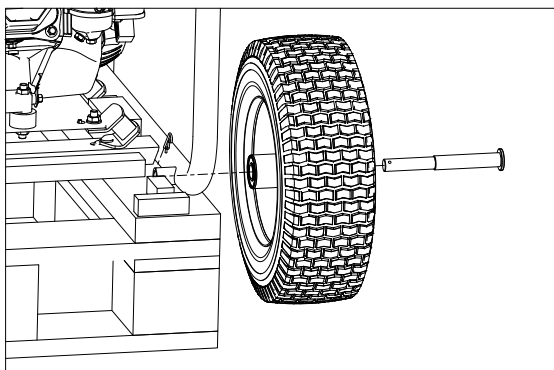

Step 4

Move the unit till the frame bottom placed on the bump of pallet (Take below images as reference)

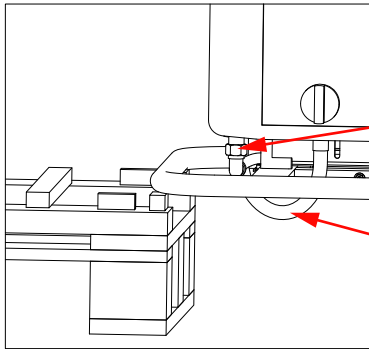
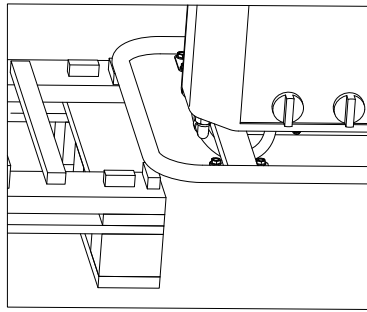
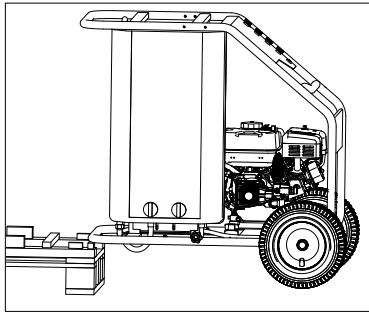

Outlet hose

LPG inlet hose

Step 5

Take out universal wheels and bolts and install wheels

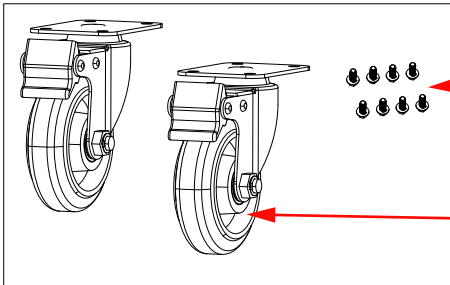

Bolts M8x16

Universal wheel

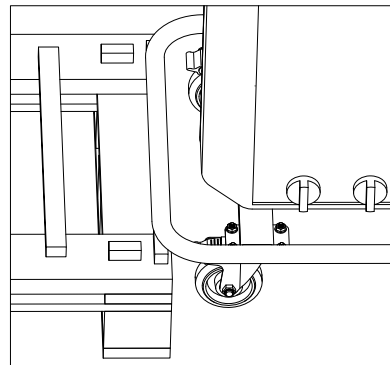
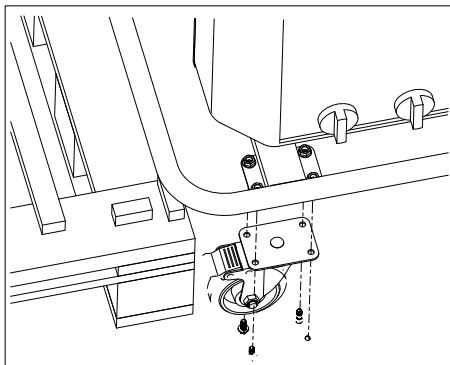



WARNING: High Pressure Fluid Injection Hazard

High-pressure fluid discharge from leaks (even pin-sized) or ruptured components can pierce skin and inject fluid into the body. Injection injury can result in blood poisoning and/or severe tissue damage leading to infection, gangrene, and possibly amputation.

- Never use a finger or skin to check for leaks.
- Never operate machine with damaged or missing hoses/parts.
- Never attempt to repair a high-pressure hose or component — Always replace it with a part that is rated at or above the pressure rating of this machine.

Step 3. Select Suitable Location

Moving and Handling

Moving your pressure washer around

- Use the handles to manually move the pressure washer.
- Push the pressure washer in front of you as you walk.
- To turn, push down slightly on the handles and pivot the pressure washer on its wheels.

Elevating or lowering your pressure washer

- To reduce risk of injury, it is recommended that two adults lift the pressure washer.
- Only lift the pressure washer by the bumper and handle. Do not use the pump or engine as a lifting point.

WARNING: Lifting Hazard

The pressure washer is heavy. It can crush and cause serious injury if it rolls out of control or tips over. Follow the instructions below for safely moving the pressure washer.

Outdoor Use Only

1. Never run the pressure washer in an enclosed or partially enclosed location such as a building, garage, barn, shed, or house. These spaces can trap poisonous gases. Running a fan or opening windows will not provide adequate ventilation to prevent dangerous CO build-up.
2. Only use the pressure washer outdoors and far away from open windows, doors, and building or vehicle vents.
3. Place the pressure washer so that the exhaust fumes will not be directed towards people or building air intakes.
4. Do not locate and use the pressure washer in the presence of flammable vapors, dust, gases, or other potentially combustible materials.
5. Note that this pressure washer is NOT designed or approved for use in vehicles or marine applications. Never run the pressure washer inside RVs or other vehicles, on boats, or on pick-up truck beds.

Positioning:

1. The pressure washer should be positioned on a firm, level (less than 3 degree slope), heat-resistant surface with good drainage and a nearby water supply.
2. The pressure washer should be placed within garden hose distance of a continuous water supply. Ensure that the pressure washer sits level and will not slide or shift during operation. If applicable, block the pressure washer's wheels to prevent movement.
3. Position the pressure washer so there is adequate pulling room for starting the engine using the recoil starter. Attempting to pull at an odd angle could rip off grip cord and/or cause muscular injuries to the operator.

Airflow:

1. Position the pressure washer so there is adequate clearance around pressure washer to allow for airflow at least 7 feet from any non-combustible wall or obstruction.
2. Do not operate with a tarp, blanket, or cover surrounding the machine.
3. Do not place any objects against or on top of the unit.
4. The pressure washer needs adequate, unobstructed flow of air to allow for proper combustion and adequate cooling. Proper combustion can only be obtained when there is a sufficient supply of oxygen available for the amount of fuel being burned. Cooling ventilation is required to prevent overheating of the pressure washer and possible fire.

Exhaust:

! WARNING: Exhaust Modification Hazard

Never attempt to attach ductwork to the muffler system to allow for installation inside an enclosure. This could cause heat build-up and increased exhaust back-pressure, resulting in possible exhaust leakage or damage to the pressure

1. The exhaust gas from your pressure washer is extremely hot and can cause combustible materials to catch on fire.
2. Make sure the engine is at least 7 feet from all combustible materials and buildings/structures during operation.

3. Keep a fire extinguisher rated "ABC" nearby. Keep it properly charged and be familiar with its use.
4. Place the unit so that the exhaust fumes will not be directed towards people or building air intakes.

! DANGER: Carbon Monoxide Hazard

Exhaust fumes from the engine contain carbon monoxide (CO), a poisonous gas you cannot see, smell, or taste. The CO generated by the engine can rapidly accumulate, even in areas that appear to be well ventilated, resulting in dangerous and fatal concentrations within minutes. NEVER run pressure washer inside any enclosed or semi-enclosed spaces, including homes, garages, basements, sheds, boxes, pick-up truck beds, RVs, or boats. These spaces can trap poisonous gases, EVEN if you run a fan or open windows. If you start to feel sick, dizzy, or weak while using the pressure washer, shut off the engine and get to fresh air RIGHT AWAY. See a doctor. You may have carbon monoxide poisoning.

Operation

Safety Rules for Operation

After you have checked and fueled the equipment and positioned it in a suitable worksite, it is time to start your pressure washer. The following are the procedures necessary for safe, successful operation of your pressure washer.

WARNING

Failure to follow safety rules may result in serious injury or death to the operator or bystanders.

Instruct operators. Owner must instruct all operators in safe set-up and operation. Do not allow anyone to operate the pressure washer who has not read the Owner's Manual and been instructed on safe use practices.

Safety equipment/controls. Always operate with all safety covers, guards, and barriers in place and in good working order, and all controls properly adjusted for safe operation.

Moving parts. Keep hands, feet, hair and apparel away from moving parts. Air vents may cover moving parts and should be avoided as well. Never remove any guards while the unit is operating.

Ear Protection. Hearing can be damaged from prolonged, close-range exposure to the type of noise produced by this pressure washer. The use of ear plugs or other hearing protection device is recommended for persons working within 15-20 feet of the running pressure washer for an extended period of time.

Eye Protection. Wear ANSI/OSHA required "Z87.1" safety glasses when operating or servicing the pressure washer. Pressurized spray from this unit can cause severe injury to the eyes. Small objects can become airborne as the spray contacts them.

NOTICE

Before starting the pressure washer, review the following general safety rules for operation:

Conditions for Use

Know how to stop. Be thoroughly familiar with proper use of the equipment and all controls and connections. Know how to stop the pressure washer and depressurize system quickly if needed.

Instruct all operators. The pressure washer's owner must instruct all operators and potential renters in safe set-up and operation. Do not allow anyone to operate the pressure washer who has not read the Owner's Manual and been instructed on its safe use.

Adult control only. Only trained adults should set up and operate the pressure washer. Do not let children operate. Pressure washers can generate forces greater than children can control and require judgment beyond what can be expected of children.

Under the influence. Never operate, or let anyone else operate, the pressure washer while fatigued or under the influence of alcohol, drugs, or medication.

Safety equipment / controls in place. Do not operate the pressure washer unless all safety covers, guards, and barriers are in place and in good working order, and all controls are properly adjusted for safe operation.

Damaged. Do not operate the pressure washer with damaged, missing, or broken parts. Never attempt to repair a high pressure hose or component. Always replace it with a part that is rated at or above the pressure rating of the machine.

Modifications. Do not modify the pressure washer in any way or deactivate any safety device. Do not change or add to fuel tank, fuel lines, or exhaust system. Modifications can result in hazards related to carbon monoxide poisoning, fuel leaks, fire, explosion or other serious safety hazards, and will also void the warranty.

During Use

Stay alert. Watch what you are doing at all times.

Clear work area. Clear the work area of all bystanders.

Keep children and pets away.

Keep spray away from electrical wiring. Spray contact with electrical wiring will likely result in severe electrical shock or electrocution.

Hot exhaust/parts. Stay clear of engine exhaust. Never touch hot engine muffler, or other hot surfaces. All are very hot and will burn you.

Never pull by hose. Do not move this machine by pulling on the hose. Hose or connections could fail and result in catastrophic high pressure release of fluid as well as hose whipping.

Avoid sharp objects. Keep hose away from sharp objects. Bursting hoses may cause injury.

No load bearing. Do not use the pump to support other items of equipment that impose unacceptable loads on the pump. Do not attempt to use this machine as a prop. **Lock trigger safety latch when not spraying.** Spray gun is equipped with a built-in trigger safety latch to guard against accidental trigger release. Rotate safety latch to the locked position when not spraying.

Leaving unattended. Always turn off the pressure washer and relieve system pressure before leaving the sprayer unattended.

Prompt Emergency Response

Seek medical aid for suspected injection injury. If injured by high-pressure fluid, no matter how small the wound is, see a doctor at once. A typical injection injury may be a small puncture wound that does not look serious. However, severe infection or reaction can result if proper medical treatment is not administered immediately by a doctor who is familiar with injection injuries.

Seek medical aid for suspected carbon monoxide poisoning. The running engine gives off carbon monoxide, a poisonous gas that can kill you. If you start to feel sick, dizzy, or weak while using the pressure washer, shut off the engine and get to fresh air RIGHT AWAY. See a doctor. You may have carbon monoxide poisoning.

Wear Personal Protective Gear

WARNING: Personal Protective Gear

Use personal protective gear to prevent:

- Eye and skin injection injury from high pressure spray
- Eye injury from flying debris

1. Wear waterproof gloves, safety glasses with side and top protection, face protection, and protective clothing when operating the machine. If spraying pressure washer specific chemicals, wear a respirator mask to avoid inhalation of vapors if directed on the chemical label.
2. Wear non-slip, protective footwear. Use of pressure washer can create puddles and slippery surfaces. Wear footwear capable of maintaining a good grip on wet surfaces.

Preparing of Operation

Make sure that any regular maintenance has been performed as prescribed in “*Maintenance & Repair*” section.

Check/Add Engine Oil

Use the recommended oil type for your engine and expected ambient conditions. (See “*Engine Manual*” section of this Owner's Manual for oil type and capacity, and more detailed oil check/fill instructions.)

WARNING: Burn Hazard

Never open oil port while engine is running. Hot oil can spray over face and body.

Note: Engine is shipped without oil. You must add oil before first use.

Add Fuel

⚠ WARNING: Fuel Fire/Explosion Hazard

Gasoline is highly flammable and explosive. Heat, sparks, and flames can ignite fuel vapors, which can become widespread during fueling. A flash fire and/or explosion could result and cause serious injury or death. Always use extreme care when handling fuels. Carefully follow all instructions to avoid the following conditions which could result in fuel ignition:

- gas vapor collection inside enclosures
- static electric sparks
- sparks from electric wiring, batteries, or running engines
- sources of heat (such as a hot engine exhaust)
- open flames, including pilot lights

Always follow these general safety rules when fueling:

1. Turn pressure washer off and allow to cool for at least two minutes before removing any fuel cap.

Note: A running or still-hot engine is hot enough to ignite fuel.

2. Fill fuel tank OUTDOORS – never indoors. Fuel vapors can ignite if they collect inside and enclosure and explosion can result.
3. Stay away from all sources of heat, sparks, and flames. Do not smoke.
4. Never pump fuel directly into the gas tank at a gas station – it could cause a static electric spark. Follow these steps to avoid static electric sparking during fueling:
 - Use an approved portable container to transfer fuel to the pressure washer's tank. (A portable container made of metal or conductive plastic is preferred because it dissipates charge to ground more readily.)
 - Always place container on the ground to be filled. Never fill the portable gas container while it is sitting inside a vehicle, trailer, trunk, or pick-up truck bed.
 - Dissipate static charge from your body before beginning the fueling process by touching a grounded metal object at a safe distance from fuel sources.
 - Keep nozzle in contact with container while filling. Do not use a nozzle lock-open device.
5. Clean up fuel spills/splashes immediately.

- If possible, move the pressure washer away from spilled fuel on the ground.
- Wipe up spilled fuel and wait 5 minutes for excess fuel to evaporate before starting engine.
- Fuel soaked rags are flammable and should be disposed of properly.
- If fuel is spilled on your skin or clothes, change clothes and wash skin immediately.

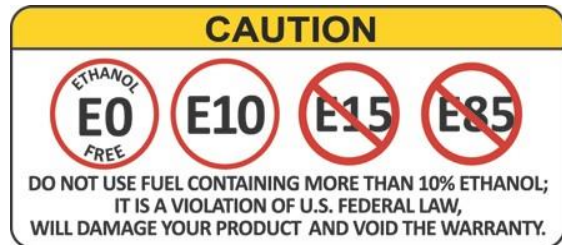

Fill Engine Fuel Tank

Check the gasoline tank level. If needed, fill tank with fresh unleaded gasoline from a portable container:

1. Remove engine gas cap.
2. Add gasoline through the fill opening:
 - Use only a UL-listed portable gasoline container to transfer the gasoline to engine's tank.
 - Do NOT overfill the gasoline tank. Allow at least 1/2" of empty space below the fill neck to allow for fuel expansion.
3. Replace gas cap securely before starting engine.
4. Store extra gasoline in a cool, dry place in a UL listed tightly sealed container.

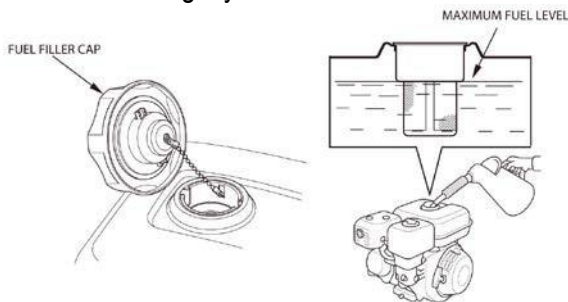

Inspect Fuel System/Check for Leaks

Inspect the engine fuel system and check for leaks before each use.

Do not start pressure washer until all needed repairs have been completed.

⚠ WARNING: Fuel Leak Hazard

Gasoline fuel is highly explosive and fuel leaks can result in fire or explosions. You can be burned and seriously injured if the fuel system is not properly hooked up or there is a fuel leak when you start the engine.

Inspect the entire fuel system. Look for:

- signs of leaks or deterioration
- chafed or spongy fuel hose
- loose connections
- loose or missing fuel hose clamps
- damaged fuel tank or
- defective gasoline shut-off valve

Inspect Spray System

Always inspect spray system for damage and leaks before each use. Do not start pressure washer until all needed repairs have been completed.

⚠ WARNING: High Pressure Fluid Injection Hazard

High-pressure fluid discharge from leaks (even pin-sized) or ruptured components can pierce skin and inject fluid into the body. Injection injury can result in blood poisoning and/or severe tissue damage leading to infection, gangrene, and possibly amputation.

- Never use a finger or skin to check for leaks.
- Never operate machine with damaged or missing hoses/parts.
- Never attempt to repair a high-pressure hose or component – Always replace it with a part that is rated at or above the pressure rating of this machine.

Perform Scheduled Maintenance, As needed

Make sure that any other regular maintenance has been performed as prescribed in this manual in the "Maintenance Schedule Summary" section.

Refer to the "Engine Manual" section of this manual for engine maintenance instructions.

Connect Hoses, Water Supply, and Spray Nozzle

Position pressure washer for use

- For detailed instruction on positioning your pressure washer for use, turn to the "Initial Set-Up" section of this manual and reference "Step 3: Select Suitable Location".
- Where no flammable vapors, dusts, and gases are present.
- Where there is adequate, unobstructed ventilation airflow.
- With adequate clearance from combustible materials.
- On a firm, level, heat-resistant surface with good drainage and nearby access to a continuous water supply.

Attach Garden Hose to Water Inlet

1. Make sure the water supply is clean. Debris can cause excess pump wear and reduce performance.
2. An insufficient water supply will damage your pump. Make sure the water supply is steady and is 20% over the rated flow of your pump. Use a stopwatch to time how long it takes to fill a 5-gallon bucket with your garden hose. The bucket must fill faster than the times listed in the table below.

Model	Time to fill 5 gallon bucket
115177	100 seconds

- The water supply garden hose must have an inside diameter of at least 5/8". If the hose is more than 100 ft. long, the diameter must be at least 3/4".
- Never use a reservoir tank as a water source. Drawing water out of a tank may cause pump cavitation and damage to your pump. This pressure washer is designed for a pressurized water source such as a city water faucet. However, the water source pressure must not exceed 115 psi (8 bar).
- Always use a flexible rubber hose for your water supply. Do not use rigid piping.

Attach High Pressure Hose to Spray Gun and Water Outlet

! WARNING: High Pressure
 NEVER operate this pump with components (such as hose, connections, and spray gun) rated for lower pressure and/or temperature limits than the machine's maximum rated pressure and temperature, or component could rupture and cause serious personal injury from escaping high pressure fluids.

- See "Component Identification" section of this manual for location of the pressure washer's water outlet.
- To attach the pressure hose to the spray gun, spin the pressure hose's coupler onto the spray gun's inlet, hand tight.

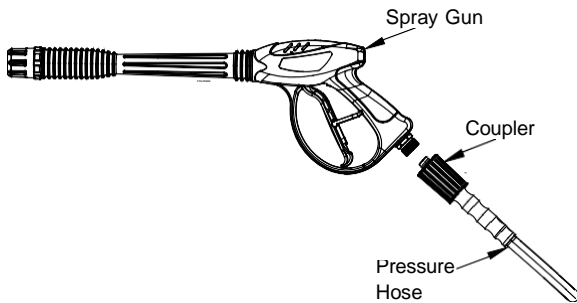

Select Nozzle for Spray Gun

Your pressure washer is equipped with (3) high-pressure nozzle and (1) low-pressure nozzle. Generally, the wider the spray angle of the nozzle, the lower the spray impact produced. Select the appropriate nozzle for the job based on the following table:

Color of Nozzle	Spray Angle	Used For
Yellow	15	Tough Stains/Stripping
Green	25	General
White	40	Light Cleaning
Black-Low pressure	65	Chemicals

Please call Powerhorse Customer Service at 1-866-443-2576 to order additional nozzles.

Note: You must use the low pressure black nozzle for spraying chemicals.

Attach Nozzle to Spray Gun

! WARNING: Depressurize First
 Any time you remove/install/change a nozzle, you must depressurize hose line by squeezing the spray gun trigger while the engine is off. Even if the engine has been off for a long period of time, the hose may remain dangerously pressurized.

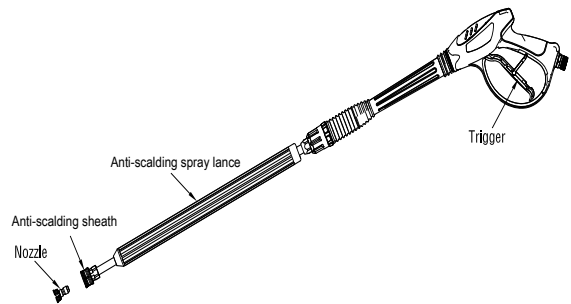

- Make sure the engine is off and the hose line is depressurized
- To install the nozzle, pull the collar back and twist the nozzle firmly into the coupler on the end of the wand

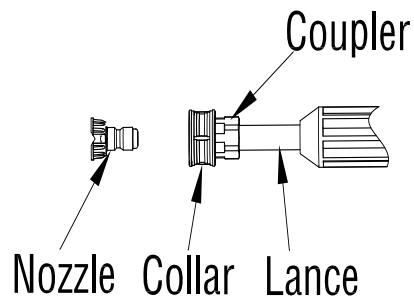

- Release the collar, making sure it springs back and re-seats to its original (non-retracted) position. Check the connection by pulling on the nozzle to ensure a tight connection -- if correctly inserted, nozzle will rotate but not pull out.

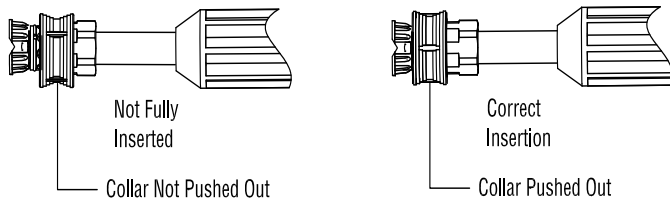

Prime the Water Supply

Turn on water supply and squeeze the trigger

CAUTION: Water Pressure

Never run the pump without the water supply connected and turned on. Operating the pressure washer without a sufficient incoming flow of water will damage the pump.

- Turn on the water supply. Make sure the water supply is steady and flowing at a rate 20% over the rated flow of your pump. (Reference the flow rate table under the "Connect Hoses, Water Supply, and Nozzle" section).
- Purge air from the water supply hose by squeezing the trigger until a steady stream of water flows out of the nozzle at low pressure. (Air in the hoses can cause damage to the pump, so always make sure all the air is out of the hoses before starting the pressure washer engine.)
- Make sure the water supply hose is not kinked. A kinked hose will provide insufficient water supply to the pump and reduce its life. Make sure the hose remains unkinked after moving the pressure washer.

Set Up for Chemical Spray (if desired)

Using the proper cleaning chemical for the application can speed up cleaning jobs tremendously.

Your pressure washer is equipped with a **chemical injection point** on the downstream side of the pump for introducing cleaning chemicals into the water stream. A chemical hose is provided to connect at this point. Suction pressure at this connection automatically draws the chemical solution in through the hose, mixing in 1 part chemical to 15 parts water. Adequate suction pressure is created only when the **low pressure (black) spray nozzle is used**.

The introduction of cleaning chemicals via the chemical injection point affords the following advantages:

- It protects the pump from damage because no chemical passes through the pump.

CAUTION: Chemicals Containing Muriatic Acid

Certain chemicals, such as bleach or those containing muriatic acid, will cause pump damage if introduced upstream through the pump's water inlet.

It mixes the cleaning chemical into a low pressure spray. Cleaning chemicals applied under low pressure adhere better to the surface being cleaned, allowing the formula time to react and remove dirt more effectively.

Note: An external *chemical injector pump* is not recommended for use with this pressure washer, and if used would obviously alter the 15-to-1 dilution ratio.

⚠ WARNING: Chemical Spraying

- Never spray acids, corrosives, or abrasive or flammable liquids. Breathing hazards, surface burns/corrosion, or fire/explosion could result.
- Follow the chemical manufacturer's label instructions for proper use and handling of the chemical. Understand all safety hazards and first aid for all chemicals being used. Always wear protective gloves when handling and cleaning with chemicals, and wear other protective gear as directed by chemical manufacturer. Always dispose of hazardous fluids per local, state, and national guidelines.

Acquire Cleaning Chemical

Use only approved pressure washer chemicals designed for high-pressure use.

CAUTION: Non-approved Chemicals

Non-approved chemicals can damage pressure washer components (seals, wand, hoses, pump, etc.) and be harmful to the environment.

Prepare for Chemical Spray (If Planning to Use)

Prepare the pressure washer for chemical spraying using the following steps:

1. Prepare (dilute) chemical cleaning solution as required for the job.
(Note: the chemical solution will be automatically mixed with the water at a ratio of 15 parts water to 1 part chemical solution.)
2. Ensure that the chemical hose is pressed onto the chemical injector on the pump.

Start-Up Procedures

Gas system ready (if hot water cleaning is required)

1. Make sure the LPG tank is mounted in the rack and fully secured.
2. Ensure that the LPG gas tank is properly connected to the gas pipe assembly and that the gas tank valve is opened.

1. Make sure water supply is connected and primed.

CAUTION: Warranty Void

Running the pump dry will cause damage and void the warranty.

2. To prevent accidental spraying, engage the safety latch on spray gun trigger by rotating it to the locked position.
3. Follow the instructions in the "Engine Manual" section of this manual for starting the engine.
 - If the engine doesn't start on the first try, pressure may build up in the pump. Relieve pressure by squeezing the spray gun trigger before attempting to start engine again. This will make starting easier.

DANGER: Engine Exhaust

Do not inhale engine exhaust. It contains dangerous carbon monoxide that can kill you.

Apply Cleaning Chemical (If Desired)

1. Make sure the chemical injector is properly set up according to the instructions. Reference "Set Up for Chemical Spray" on the previous page.
2. Make sure the low pressure BLACK nozzle is attached before beginning to spray chemicals -- **Only the low pressure black nozzle will allow chemicals to be drawn through the chemical injector into the water stream.**
3. Apply chemicals by squeezing the spray gun trigger. The chemical injector will draw the chemical into the water stream.
4. Apply chemicals evenly to the cleaning surface. Never use more chemical than is necessary to clean the surface.
5. Allow the chemicals time to react with the dirt before rinsing.
6. Prepare to rinse by changing to a high-pressure nozzle. Changing the nozzle from the low-pressure black nozzle to a high-pressure nozzle will stop the flow of chemicals into the water stream.

Instructions for selecting a nozzle can be referenced in the "Connect Hoses, Water Supply, and Spray Nozzle" section. Also see the subsection "Select Nozzle for Spray Gun".
7. Rinse with high-pressure spray as instructed below.

Pump Components

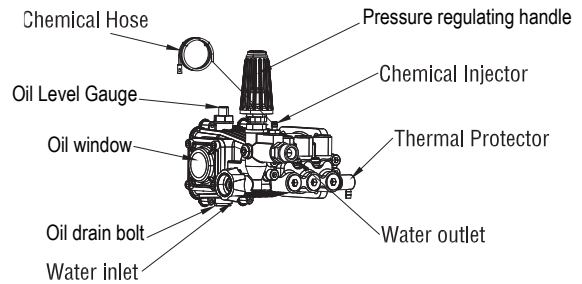

Water heater components

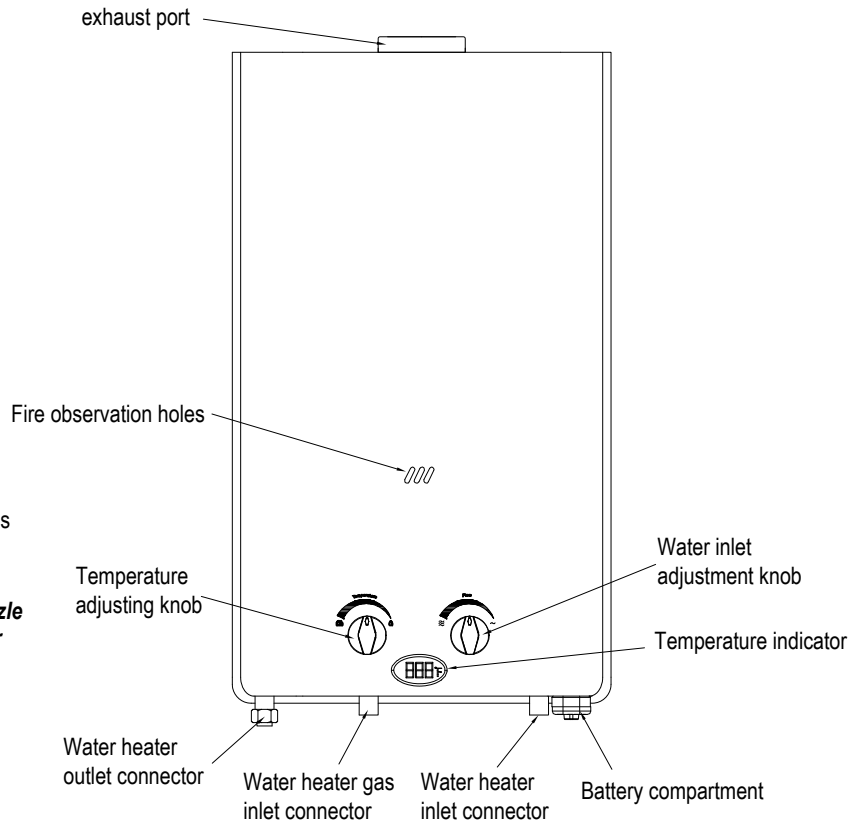

Begin High Pressure Spray

WARNING: High Pressure Spraying Safety

- **Keep spray away from people.** Never direct discharge stream at or near any person. Do not allow any part of the body to come in contact with the fluid stream. High-pressure spray can cause serious skin, eye, or falling injuries. Injection injury will occur if high-pressure spray pierces the skin, injecting liquid under the skin. Injection injury can result in blood poisoning and/or severe tissue damage leading to infection, gangrene and possibly amputation. Seek medical attention.
- **Do not secure trigger open.** To reduce risk of injury, do not attempt to secure the spray gun open by blocking or tying the spray gun in the open position.
- **Prevent slips / loss of balance.** High-pressure spray could cause you to lose balance from kickback forces, and wet surfaces can be slippery.
 - Keep good footing and balance at all times. Do not overreach.
 - Do not stand on unstable support when spraying.
 - If spraying from an elevated surface, use fall protection because spray gun kickback can propel you off the elevated surface. When spraying from a ladder or scaffolding, ensure it is firmly anchored from sway or tip-over.
 - Be aware of puddles and slippery surfaces. Ensure there is adequate drainage to prevent pooling of water.
- **Prevent surface damage & flying debris** – Surfaces being sprayed must be strong enough to withstand high-pressure spray or damage may result. In addition, high-pressure spray will dislodge unsecured objects as well as surface chips and debris, resulting in hazardous flying objects that can cause personal injury or property damage. Do not spray brittle surfaces or breakable, fragile, or unsecured objects such as:
 - stucco or laminar flagstone
 - some painted surfaces
 - windows or glass doors (because they may break)
 - light fixtures, flowerbeds, mailboxes
 - unsecured, lightweight objects
- **Prevent burns**
 - When using hot water for cleaning, do not touch the metal parts of the water pipes at the back of the water heater, which will cause a risk of burns.
 - When using hot water for cleaning, do not touch the smoke vent of the water heater, there will be a risk of burns.

Procedure:

1. Install one of the high-pressure spray nozzle (always relieve system pressure first and follow instructions for attaching a nozzle).
2. Clear the cleaning area of all persons. Keep children and pets away.
3. Hold the spray gun firmly with two hands and a sturdy stance -- Gun kicks back when triggered.
4. Wash from the bottom to the top, using side-to-side motions. This washes away heavy dirt and allows the detergent to soak as you work toward the top.
5. Use the width of the spray pattern to wash a wide path. Overlap spray paths for complete coverage.
6. The nozzle should be 12" to 24" from the work, closer for tough areas.
7. Small parts should be washed in a basket so the pressure does not push them away. Larger, lightweight parts should be clamped down.
8. The pressure washer is set and locked to the maximum rated pressure when it leaves the factory.

WARNING: High Pressure Fluid Hazard

Do not attempt to alter the unloader valve's maximum pressure. Excess pressure could cause serious injury from escaping high-pressure fluids and/or pump damage. Any alteration other than turning the adjustment knob will void your warranty.

9. If temporarily interrupting spraying, rotate trigger safety latch downward to the locked position to guard against accidental trigger release.

Spray Gun Safety Lock

When not spraying, use the spray gun safety lock to prevent accidental high pressure discharge.

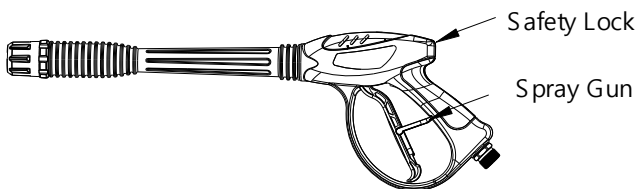

10. Always turn off the engine and activate spray gun trigger to relieve system pressure when:
 - the sprayer is unattended
 - disconnecting hoses, installing/cleaning nozzles, or servicing the pump.

WARNING: High Pressure Fluid Hazard

Always turn off the engine and relieve system pressure when finished spraying or when leaving sprayer unattended. Serious injury could result from unintentional release of high-pressure spray.

Shutdown

Stop the engine using the following steps:

WARNING: High Pressure Fluid Hazard

Never disconnect the high-pressure hose from the pump or spray gun while the system is pressurized. Relieve pressure by squeezing the spray gun trigger after the engine is turned OFF.

1. Close the LPG tank valve
2. Turn engine OFF.
3. Turn water supply OFF.
4. Actuate spray gun trigger to relieve system pressure.
5. Remove garden hose.
6. Remove pressure hose.
7. Remove nozzle from spray gun.
8. Turn gasoline line valve to the OFF position.
9. If chemicals were used, remove chemical injector tube from the pump.
10. Cool engine at least five minutes before storing, a hot engine is a fire hazard

Storage

When you are finished using the pressure washer, you must prepare the sprayer for storage and store it in a proper location.

Between-Use Storage

Perform periodic maintenance as directed in this manual to keep the pressure washer in safe working condition.

Choose a storage location that is:

- Clean and dry.
- Away from sources of heat, open flames, sparks, or pilot lights, even if the pressure washer's engine fuel tank is empty. Residual fuel fumes from tank can ignite.
- Away from extreme high or low temperatures. Do not store the pressure washer in freezing conditions unless it is prepared as directed below for those conditions.

Note:

- **If you will be storing the pressure washer in freezing conditions**, follow the instructions for preparing the sprayer for storage in freezing conditions.
- **If you will not be using the pressure washer again for 30 days or more**, follow the instructions for preparing the engine for long-term storage.

⚠ WARNING: Flammable Materials

- **Fuel and its vapors can ignite and cause a fire.** Select a well-ventilated storage area away from sources of heat, flame, or sparks.
- **A hot engine can ignite flammable materials.** Always let engine cool at least five minutes before storing.

Prepare Pressure Washer for Freezing Conditions

If you will be storing the pressure washer in freezing temperatures, you must properly prepare the pressure washer to prevent water from freezing in the system.

⚠ WARNING: Freezing Conditions

Do not allow water to freeze in the pressure washer, high pressure hose, or spray gun. Freezing water can cause damage to the equipment and cause the spray gun to fail in the open position. A spray gun that has failed in the open position can whip around and cause personal injury when the pressure washer is started

1. Drain the water from the high pressure hose and spray gun by depressing the trigger on the spray gun until all water drains out.
2. Disconnect the plumbing that connects to the pump outlet.
3. Obtain the materials you will need:
 - 12" piece of garden hose or equivalent
 - funnel
 - approximately 6 oz. of RV antifreeze
4. Attach the 12" garden hose piece with the funnel to the pump inlet.
5. Pour RV antifreeze into the funnel, then pull the recoil a few times until antifreeze comes out of the pump outlet.

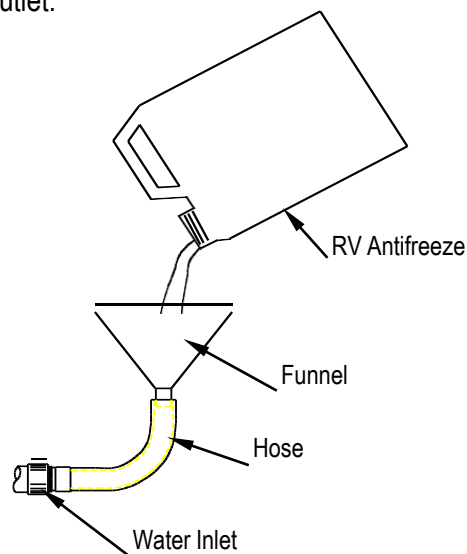

Prepare Engine for Long Term Storage

First prepare the engine for long term storage if you will not be using the pressure washer for more than 30 days.

Fuel can become stale when stored over 30 days. Stale fuel causes acid and gum deposits to form in the fuel system which can cause malfunction of the engine.

1. Prepare fuel system for storage:
 - **Drain all gasoline** from the tank and carburetor. This is most easily accomplished by *running the pressure washer with the high pressure hose* until the engine stops from lack of fuel.

OR

- **Add fuel stabilizer** to the gasoline (following manufacturer's instructions)
 - Fuel stabilizer steps:
 - a. Ensure gas tank is full.
 - b. Add fuel stabilizer to fuel tank.
 - c. *Run pressure washer with high pressure hose* at least 5 minutes after adding stabilizer to allow it to enter the fuel system.
 - d. Shut off engine
2. Lubricate cylinder and piston:
 - a. Disconnect spark plug wire and remove spark plug
 - b. Add one teaspoon oil through spark plug hole
 - c. Place rag over spark plug hole and slowly pull the recoil a few times to lubricate the combustion chamber

Replace spark plug, but do not reconnect the spark plug wire.

Prepare Pressure Washer for Storage

Prepare the pressure washer for storage.

1. Make sure the engine start switch is OFF.
2. Disconnect the engine spark plug wire if you haven't already done so.
3. Disconnect the high-pressure hose, garden hose, and spray gun.

Move Pressure Washer to Storage Location

Let engine cool for 5 minutes before moving the pressure washer to its storage location.

Maintenance & Repair

⚠ WARNING: Maintenance Hazards

ALWAYS shut off water supply, bleed water pressure, turn off engine and disconnect the spark plug wire before cleaning, adjusting, or servicing the pressure washer. After servicing, make sure all guards and cover shields are replaced before using.

Maintenance Schedule Summary

Item	Frequency
Remove dust/debris accumulation	As needed
Inspect fuel system	Each use
Inspect spray system	Each use
Check engine oil	Each use
Clean inlet filter	Each use
Perform engine maintenance	As specified in the "Engine Manual" section

See detailed instructions for each maintenance item below.

(Note: For end-of-the-season storage instructions, see the "Storage" section of this manual.)

See detailed instructions for each maintenance item below.

Detailed Instructions – Maintenance & Repair

No modifications. Never modify or alter the pressure washer in any way. Modifications can create serious safety hazards and will also void the warranty.

Follow Safety Rules

Read and follow these safety rules whenever you will be servicing the pressure washer:

- **Turn off / relieve pressure first.** Always turn off pressure washer and relieve system pressure before inspection or maintenance. Remove spark plug or spark plug wire to prevent accidental starting.
- **Fuel valve off.** Turn fuel shut-off valve to OFF position before transporting or servicing the pressure washer.
- **Replace guards.** Make sure all guards and cover shields are replaced after servicing the pressure washer.
- **Major repair.** Major service, including the installation or replacement of parts, should be performed only by a qualified service technician. Obtain factory approved parts from Powerhorse Product Support at 1-866-443-2576.

- **Replacement parts.** If a part needs replacement, only use factory approved repair parts. Replacement parts that do not meet specifications may result in a safety hazard or poor operation of the pressure washer and will void the warranty.

Keep Pressure Washer Clean

If dust or debris accumulates on the pressure washer, clean the pressure washer with a damp cloth or soft bristle brush. Do not allow air intakes to become blocked.

CAUTION

Do not spray pressure washer with a garden hose or pressure washer. Water may enter the pressure washer and cause damage.

Inspect Spray System

Inspect spray system for damage and leaks before each use.

Do not start pressure washer until all needed repairs have been completed.

⚠ WARNING: High Pressure Fluid Injection Hazard

High pressure fluid discharge from leaks (even pin-sized) or ruptured components can pierce skin and inject fluid into the body. Injection injury can result in blood poisoning and/or severe tissue damage leading to infection, gangrene, and possibly amputation.

- Never use a finger or skin to check for leaks.
- Never operate machine with damaged or missing hoses/parts.
- Never attempt to repair a high-pressure hose or component – Always replace it with a part that is rated at or above the pressure rating of this machine.
- Check hoses, fittings, wand, trigger gun and connections for signs of wear, cracks, looseness, or leaks. Replace as required.
- Check and clean the nozzle orifice.

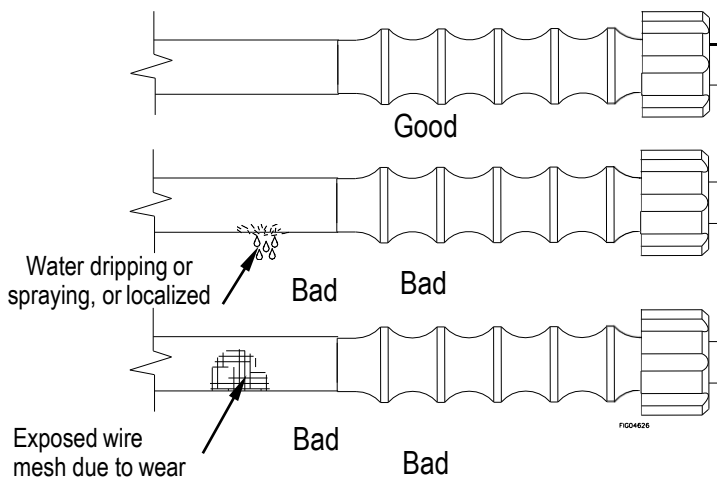

Inspect Fuel System

Inspect the engine fuel system and check for leaks before each use.

Do not start pressure washer until all needed repairs have been completed.

⚠ WARNING: Filter Disposal

Gasoline fuel is highly explosive and fuel leaks can result in fire or explosions. You can be burned and seriously injured if the fuel system is not properly hooked up or there is a fuel leak when you start the engine.

Inspect the entire fuel system. Look for:

- signs of leaks or deterioration,
- chafed or spongy fuel hose,
- loose connections,
- loose or missing fuel hose clamps,
- damaged fuel tank, or
- defective gasoline shut-off valve.

Perform Engine Maintenance

-As specified in the *“Engine Manual”* section.

Engine maintenance items include:

1. Changing oil
2. Air filter check/replacement
3. Spark plug cleaning and replacement
4. Fuel filter check/replacement

Inspecting and cleaning muffler (and spark arrestor if equipped)

Check the LPG gas tank connection system

Check the LPG gas tank linked to hot water before each use to check that there is no leakage.

Do not start pressure washer until all needed repairs have been completed.

COMMERCIAL USERS:

All mechanical equipment, no matter how well designed, will need maintenance and repairs. A Powerhorse pressure washer is no exception. At times, a Powerhorse pressure washer may become inoperable because repairs are required. Powerhorse Product Support will assist in these repairs as needed, but if an inoperable pressure washer creates a major expense to your business, then we strongly recommend the following:

- Have a staff person become familiar with the mechanical operation of the pressure washer and capable of making minor repairs and performing all preventative maintenance procedures.
- Keep a stock of recommended service parts for maintenance and minor repairs.

IMPORTANT: Replacement Parts

If a part needs replacement, only use parts that meet the manufacturer's part number specifications. Replacement parts that do not meet specifications may result in a safety hazard or poor operation of the pressure washer.

**Contact Powerhorse Product Support at
1-866-443-2576 for any
questions, problems, or parts orders.**

Troubleshooting

This section provides a list of the more frequently encountered pressure washer malfunctions, their causes and corrective actions. Some corrective actions can be performed by the operator or maintenance personnel, and others may require assistance of a qualified electrician or Service Center.

ENGINE WILL NOT START	
Causes	Solutions
Low Oil Shutdown	Fill engine with the adequate amount of oil
Cold Engine	Choke engine to start
No Fuel	Add gas to fuel tank - Make sure fuel shutoff valve is open
Engine not turned ON	Place ON/OFF switch in the ON position
Spark plug wire not attached	Attach spark plug wire to spark plug
LOW/SURGING PRESSURE	
Causes	Solutions
Insufficient water supply	Increase water flow - Check for kinked or pinched hose
Plugged inlet screen	Pull out and clean screen carefully
Need to use a high pressure nozzle	Change to the yellow, green or white nozzle
Plugged nozzle	Remove nozzle, check for blockage
Worn nozzle	Replace nozzle
Leak in high pressure line	Fix leaks
NO CHEMICAL INJECTION	
Causes	Solutions
Need to use low pressure soap nozzle	Change to the black nozzle
Back pressure from extra-long hose	Try shorter high pressure hose
Leak in clear chemical hose	Replace hose. Use hose clamps if necessary
Chemical tube is not submerged in chemical tank	Make sure chemical tube is connected and submerged into chemical tank
The water heater does not start	
Causes	Solutions
No LPG fuel	Open the LPG tank valve
Low inlet water pressure	Connect to the tap to ensure that the water pressure is 0.3-0.5MPa
Insufficient water intake	Access water source that flow is greater than 3.6 GPM
The battery power is low	Replace 2 new D(1.5V) batteries

Parts Explosion - Model 115177 - Rev A.1

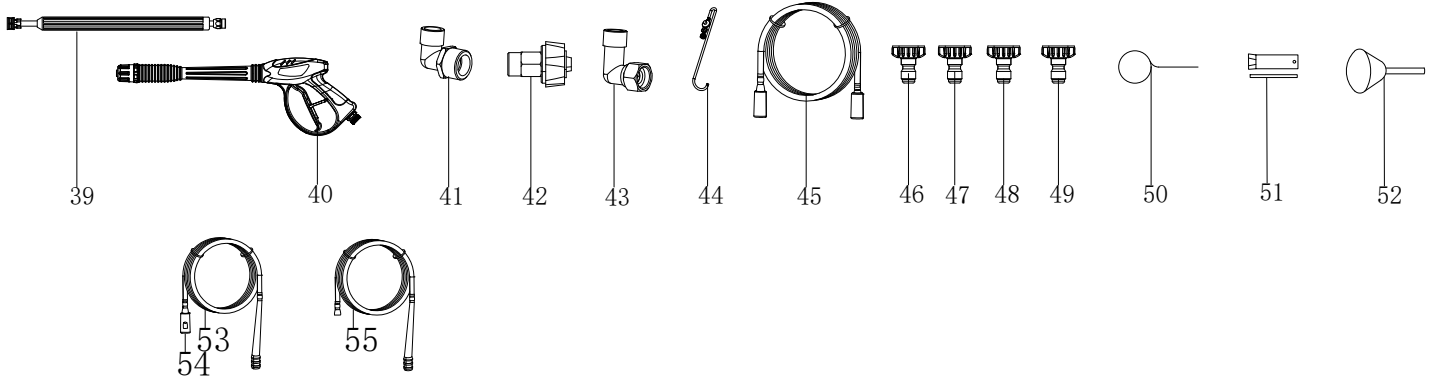
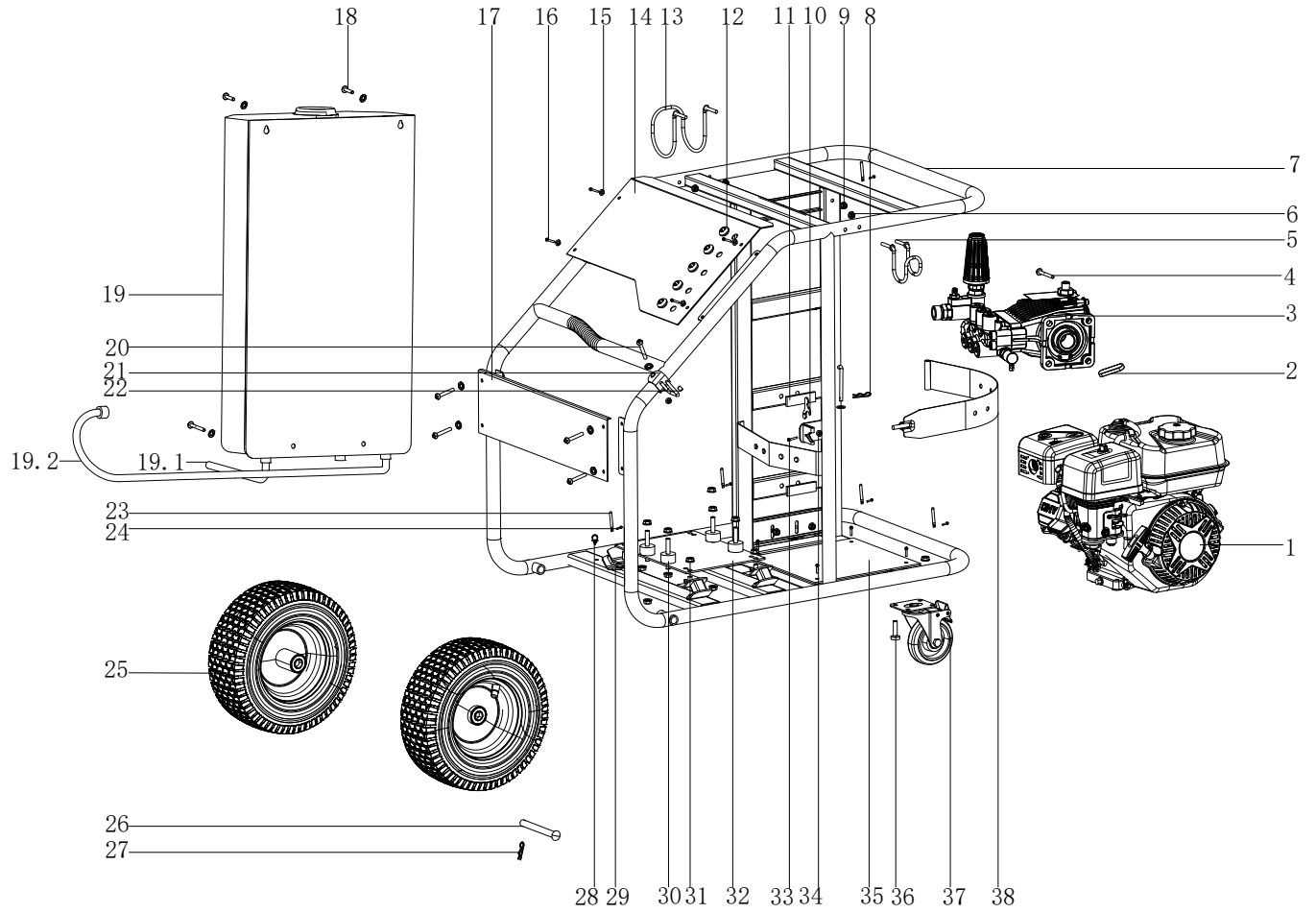

Parts List - Model 115177- RevA.1

Ref No.	Part Number	Description	Qty
1	PH115177.1	ENGINE DH212	1
2	PH115177.2	FLAT KEY	1
3	PH115177.3	WATER PUMP	1
4	PH115177.4	THE IMPERIAL BOLTS	4
5	PH115177.5	UPPER GUN HOLDER	1
6	PH115177.6	NUT M6*12	4
7	PH115177.7	FRAME	1
8	PH115177.8	WHEEL PIN	1
9	PH115177.9	NUT M6	5
10	PH115177.10	LATCH	1
11	PH115177.11	ENGINE MOUNT, VIBRATION ISOLATOR	6
12	PH115177.12	NOZZLE SET	5
13	PH115177.13	HP PIPE HOOK	1
14	PH115177.14	BILLBOARD	1
15	PH115177.15	FLAT MAT Ø6	14
16	PH115177.16	BOLT M6*12	12
17	PH115177.17	BILLBOARD	1
18	PH115177.18	BOLT M6*30	2
19	PH115177.19	WATER HEATER	1
19.1	PH115177.19.1	WATER INLET	1
19.2	PH115177.19.2	WATER PIPE COMP	1
20	PH115177.20	BOLT M6*40	1
21	PH115177.21	LOWER GUN HOLDER	1
22	PH115177.22	CAP,CENTRIFUGAL COVER	1
23	PH115177.23	METAL CLAMP	5
24	PH115177.24	BOLT M6*16	7
25	PH115177.25	WHEEL	2
26	PH115177.26	WHEEL AXLE	2
27	PH115177.27	WHEEL PIN	2
28	PH115177.28	CLIP	1
29	PH115177.29	ENGINE MOUNT, VIBRATION ISOLATOR	4
30	PH115177.30	ENGINE MOUNT, VIBRATION ISOLATOR	4
31	PH115177.31	NUT M8	16
32	PH115177.32	ENGINE ASSEMBLY PLATE	1
33	PH115177.33	SCREW M4*10	1
34	PH115177.34	NUT M4	1
35	PH115177.35	ENGINE ASSEMBLY PLATE	1
36	PH115177.36	BOLT M8*16	8
37	PH115177.37	WHEEL	2
38	PH115177.38	PROPANE TANK FIXING BELT	1
39	PH115177.39	WAND	1
40	PH115177.40	SPRAY GUN	1
41	PH115177.41	CONNECTOR, HEATER OUTLET PIPE TO PUMP	1
42	PH115177.42	CONNECTOR , WATER TAP TO HEATER INLET PIPE	1
43	PH115177.43	CONNECTOR, HEATER OUTLET PORT TO PIPE	1
44	PH115177.44	RELIEF VALVE ASSEMBLY	1
45	PH115177.45	HIGH PRESSURE PIPE	1
46	PH115177.46	NOZZLE, YELLOW 15 DEG. QC	1
47	PH115177.47	NOZZLE, GREEN 25 DEG. QC	1
48	PH115177.48	NOZZLE, WHITE 40 DEG. QC	1
49	PH115177.49	NOZZLE, BLACK SOAP QC	1
50	PH115177.50	NOZZLE CLEANER	1
51	PH115177.51	SPARK PLUG SLEEVE	1
52	PH115177.52	FUNNEL	1
53	PH115177.53	LIQUID SUCTION HOSE	1
54	PH115177.54	SUCTION FLUID MESH	1
55	PH115177.55	PUT FLUID HOSE	1

PUMP EXPLOSION

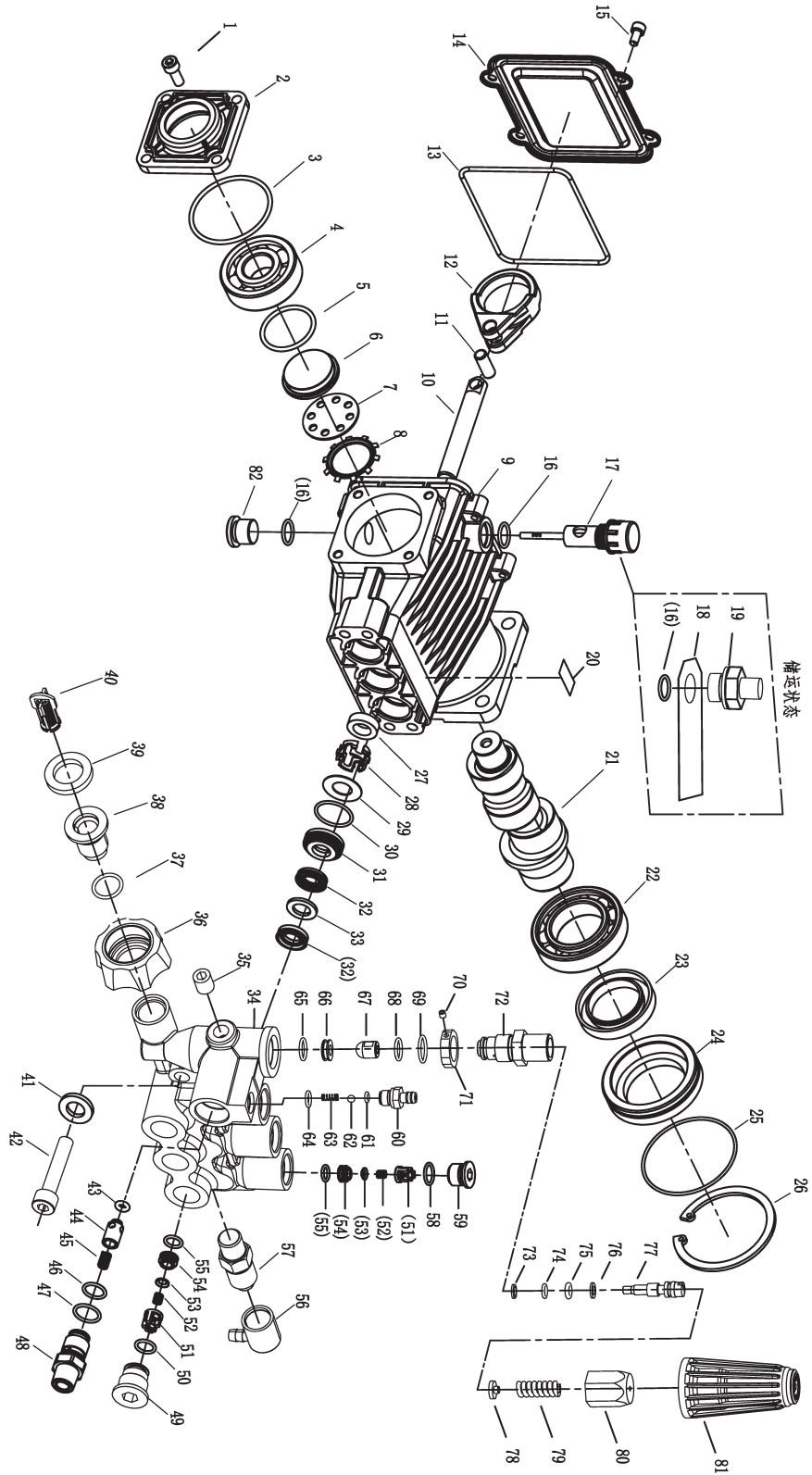

PUMP PARTS LIST

Ref No.	Description	Kit No.	Qty
1	Screw M6x16-8.8 grade	N/A	4
2	Bearing cover (black)	N/A	1
3	O-ring 51.5x2.65	N/A	1
4	Deep groove ball bearing 6304	N/A	1
5	O-ring 32.5*2.65	N/A	1
6	Oil window	N/A	1
7	Oil window gasket	N/A	1
8	jump ring	N/A	1
9	Box (metalworking)	N/A	1
10	Plunger	N/A	3
11	Link pin	N/A	3
12	Connecting rod	N/A	3
13	Box cover sealing ring	N/A	1
14	Tank cap	N/A	1
15	Screw M5x10-8.8 grade	N/A	4
16	O-ring 13.2x1.8	Kit 6	3
17	Breather plug	Kit 6	1
18	Warning listing	N/A	1
19	Stud plug	N/A	1
20	Universal label 2	N/A	1
21	Eccentric axis	N/A	1
22	Deep groove ball bearing 6007	N/A	1
23	Rotary oil seal 35528	N/A	1
24	Rotating oil jacket	N/A	1
25	O-ring 61.5x1.8	N/A	1
26	Retaining ring 65	N/A	1
27	Oil seal 12x20x6	Kit 1	3
28	Locating sleeve	Kit 1	3
29	Washer	Kit 1	3
30	O-ring 22.4x1.8	Kit 1	3
31	Packing Support	Kit 1	3
32	Water seal 12x20x5.3/2.8	Kit 1	6
33	Gasket 12*20*1.9	Kit 1	3
34	Pump head	N/A	1
35	R 1/8 laryngeal plug -8.8 grade	N/A	1
36	Hand tight nut	Kit 7	1
37	O-ring 14*1.8	Kit 7	1
38	Inlet joint	Kit 7	1
39	Rubber washer	Kit 7	1
40	Inlet screen	Kit 7	1
41	Double knurled butterfly washer 8 dacromet	N/A	4

Ref No.	Description	Kit No.	Qty
42	Hexagon socket head cap screw M8 * 40 Grade 12.9 (Dacromet)	N/A	4
43	O-ring 4.5*2.65	Kit 3	1
44	Check valve core	Kit 3	1
45	Check valve spring	Kit 3	1
46	O-ring 12.5*1.8	Kit 3	1
47	O-ring 15*1.8	Kit 3	1
48	3/8 Outlet connector	Kit 3	1
49	Water inflow	N/A	3
50	O-ring 10.6*1.8	Kit 2	3
51	Valve cover	Kit 2	6
52	Inlet and outlet valve spring	Kit 2	6
53	Inlet and outlet valve gasket	Kit 2	6
54	Valve seat	Kit 2	6
55	O-ring 9*1.8	Kit 2	6
56	Water outlet sleeve of thermal protector	Kit 5	1
57	Temperature control valve	Kit 5	1
58	O-ring 13.2*1.8	Kit 2	3
59	Outlet of the water	N/A	3
60	Fixed Injector	Kit 3	1
61	O-ring 3.68*1.78	Kit 3	1
62	Steel ball φ3/16	Kit 3	1
63	Suction spring	Kit 3	1
64	O-ring 7*1	Kit 3	1
65	O-ring 11.2*1.8	Kit 4	1
66	Tapered valve seat	Kit 4	1
67	Valve core head	Kit 4	1
68	O-ring 11.8*1.8	Kit 4	1
69	O-ring 15*1.8	Kit 4	1
70	M4*4	Kit 4	1
71	Limit washer	Kit 4	1
72	Valve body	Kit 4	1
73	Anti-extrusion ring	Kit 4	1
74	O-ring 6.3*1.8	Kit 4	1
75	O-ring 7.1*1.8	Kit 4	1
76	Washer	Kit 4	1
77	Valve Core	Kit 4	1
78	Anti-extrusion ring	Kit 4	1
79	Valve core	Kit 4	1
80	Spring washer	Kit 4	1
81	Pressure regulating spring	Kit 4	1
82	Drain plug	Kit 6	1

PUMP KIT PARTS LIST

Kit No.	Kit Description	Ref No.	Description	Qty	Kit Part Number
1	Seal kit	27	Oil seal 12x20x6	3	PH115177.PK1
		28	Locating sleeve	3	
		29	Washer	3	
		30	O-ring 22.4x1.8	3	
		31	Packing Support	3	
		32	Water seal 12x20x5.3/2.8	6	
		33	Gasket 12*20*1.9	3	
2	Valve kit	50	O-ring 10.6*1.8	3	PH115177.PK2
		51	Valve cover	6	
		52	Inlet and outlet valve spring	6	
		53	Inlet and outlet valve gasket	6	
		54	Valve seat	1	
		55	O-ring 9*1.8	6	
3	Outlet Kit w/Injector	58	O-ring 13.2*1.8	3	PH115177.PK3
		60	Fixed Injector	1	
		61	O-ring 3.68*1.78	1	
		62	Steel ball ϕ 3/16	1	
		63	Suction spring	1	
		64	O-ring 7*1	1	
		43	O-ring 4.5*2.65	1	
		44	Check valve core	1	
		45	Check valve spring	1	
		46	O-ring 12.5*1.8	2	
		47	O-ring 15*1.8	1	
4	Unloader Manifold Kit	48	3/8 Outlet connector	1	PH115177.PK4
		65	O-ring 11.2*1.8	1	
		66	Tapered valve seat	4	
		67	Valve core head	1	
		68	O-ring 11.8*1.8	1	
		69	O-ring 15*1.8	1	
		70	M4*4	1	
		71	Limit washer	1	
		72	Valve body	1	
		73	Anti-extrusion ring	1	
		74	O-ring 6.3*1.8	1	
		75	O-ring 7.1*1.8	1	
		76	Anti-extrusion ring	1	
		77	Valve core	1	
		78	Spring washer	1	
79	Pressure regulating spring	1			
80	Valve cover	1			
81	Pressure regulating handle	1			
5	Thermal Relief Kit	56	Water outlet sleeve of thermal protector	1	PH115177.PK5
		57	Temperature control valve	1	
6	Inlet Plug & Dipstick Kit	16	O-ring 13.2x1.8	3	PH115177.PK6
		17	Breather plug	1	
		82	Drain plug	1	
7	Inlet Filter Kit	36	Hand tight nut	1	PH115177.PK7
		37	O-ring 14*1.8	1	
		38	Inlet joint	1	
		39	Rubber washer	1	
		40	Inlet screen	1	

Engine Explosion

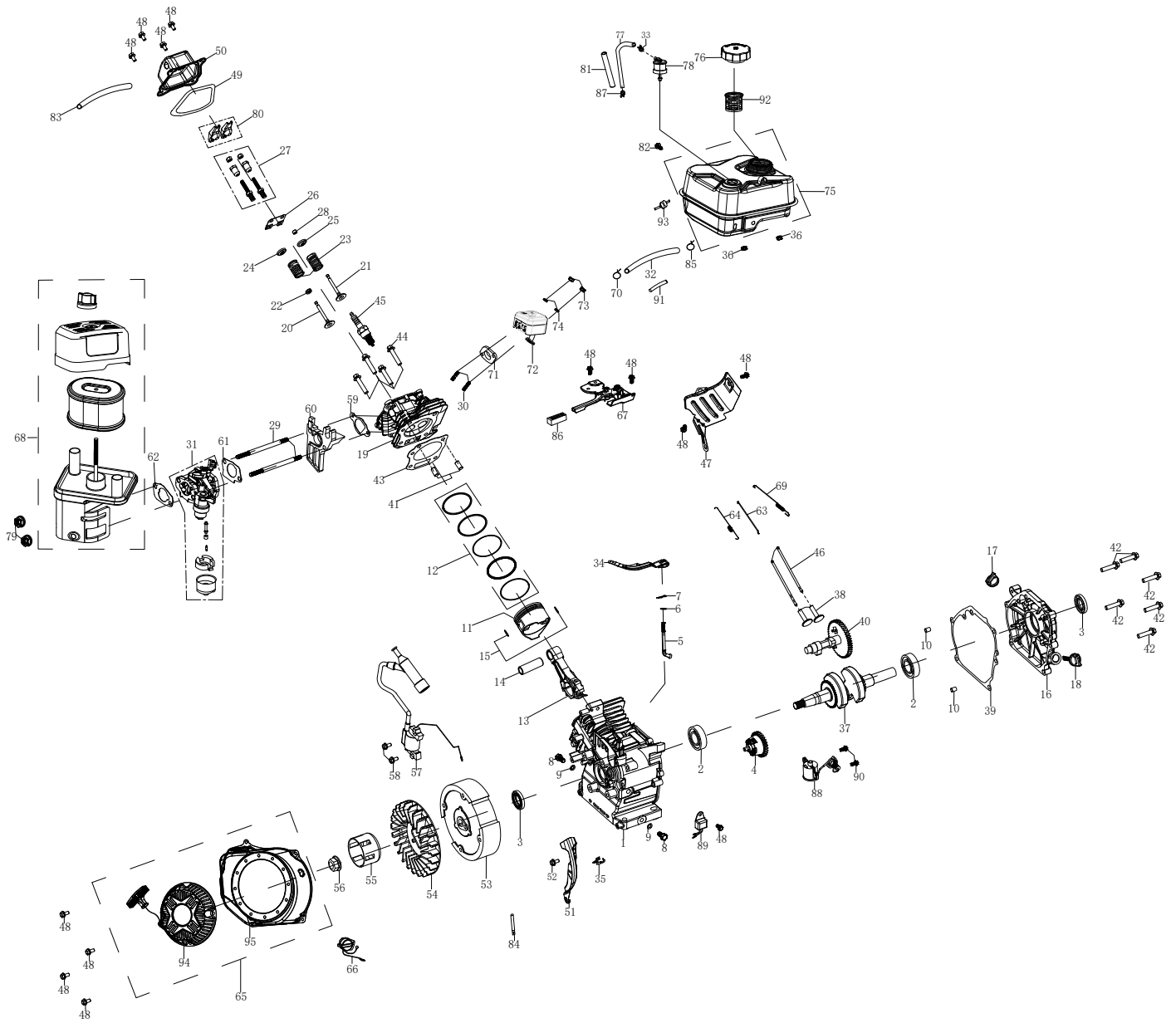

Engine Parts List

Ref No.	Part No. or Kit No.	Description	Qty
1	N/A	CRANKCASE	1
2	KIT 12	BALL BEARING	2
3		OIL SEAL	2
4	N/A	GOVERNOR ASSEMBLY	1
5	KIT 4	SHAFT, GOVERNOR ARM	1
6		WASHER, GOVERNOR ARM SHAFT	1
7		PIN, LOCK	1
8	KIT 1	BOLT, DRAIN PLUG	2
9		WASHER, DRAIN PLUG	2
10	KIT 12	DOWEL PIN, CASE COVER	2
11	N/A	PISTON	1
12	N/A	SCRAPER RING SET, PISTON	1
13	N/A	ROD ASSEMBLY, CONNECTING	1
14	N/A	PIN, PISTON	1
15	N/A	CLIP, PISTON	2
16	KIT 12	COVER ASSEMBLY, CRANKCASE	1
17	PH115177.E17	OIL PLUG	1
18	PH115177.E18	DIPSTICK	1
19	N/A	CYLINDER HEAD	1
20	N/A	VALVE, IN	1
21	N/A	VALVE EXHAUST	1
22	N/A	RETURNER, INTAKE VALVE	1
23	N/A	SPRING, VALVE	2
24	N/A	SEAT, VALVE SPRING, IN	1
25	N/A	SEAT, VALVE SPRING, EX	1
26	N/A	PLATE, PUSH ROD GUIDE	1
27	N/A	ROCKER ARM TIGHTENING BOLTS	2
28	N/A	ROTATOR	1
29	KIT 11	BOLT, STUD	2
30	KIT 13	BOLT, STUD	2
31	KIT 11	CARBURETOR ASSEMBLY	1
32	KIT 6	FUEL LINE	1
33		CLIP, FUEL LINE Φ 10	1
34	KIT 4	GOVERNOR ARM	1
35	N/A	CLIP	1
36	KIT 6	NUT M6	2
37	N/A	CRANKSHAFT ASSEMBLY	1
38	N/A	LIFTER, VALVE	2
39	KIT 12	PACKING, CASE COVER	1
40	N/A	CAMSHAFT ASSEMBLY	1
41	N/A	PIN, DOWEL	2
42	KIT 12	BOLT M8X30	6
43	N/A	GASKET, CYLINDER HEAD	1
44	N/A	BOLT M8X60	4
45	PH115177.E45	SPARK PLUG	1
46	N/A	ROD, PUSH	2
47	N/A	SHROUD	1
48	KIT 2, KIT 3, KIT 5, KIT 9	BOLT M6X12	13
49	KIT 3	PACKING, HEAD COVER	1
50		COVER COMP, CYLINDER HEAD	1
51	N/A	WIND SHIELD COMP.	1
52	N/A	BOLT M6X20	1
53	N/A	FLYWHEEL ASSEMBLY	1
54	KIT 8	FAN, RECOIL STARTER	1
55		PULLEY, STARTER	1
56		NUT	1
57	KIT 10	IGNITION COIL ASSY	1

Ref No.	Part No. or Kit No.	Description	Qty
58	KIT 10	BOLT M6X25	2
59	KIT 11	PACKING, INTAKE	1
60		INSULATOR, CARBURETOR	1
61		PACKING, CARBURETOR	1
62	KIT 7 KIT 11	AIR FILTER GASKET	1
63	KIT 4	ROD, GOVERNOR	1
64		SPRING, THROTTLE RETURN	1
65	KIT 5	RECOIL STARTER ASSEMBLY	1
66	PH115177.E66	SWITCH ASSEMBLY	1
67	KIT 2	SHROUD ASSY, UPPER	1
68	KIT 7	AIR CLEANER ASSEMBLY	1
68A	KIT 7 or PH115177.E68A	AIR FILTER ELEMENT	1
69	KIT 4	SPRING, GOVERNOR	1
70	KIT 6	CLIP, FUEL LINE Φ 7.5	1
71	KIT 13	PACKING, EXHAUST	1
72		MUFFLER COMP	1
73		NUT M8	2
74		SPRING WASHER	2
75	KIT 6	FUEL TANK ASSEMBLY	1
76	KIT 6 or PH115177.E76	THE CAP	1
77	KIT 6	CONNECTING PIPE	1
78		MANUAL CHOKE ASSEMBLY	1
79	KIT 7	NUT M6	2
80	N/A	ROCKER ARM VENTILATION TUBE	2
81	KIT 6	PROTECTOR BOLT M6X28	1
82			
83	KIT 7	TUBE, BREATHER	1
84	N/A	CLIP, WIRE HARNESS	1
85	KIT 6	CLIP, FUEL LINE Φ 9.5*0.8	1
86	KIT 2	SPEED REGULATING HANDLE	1
87	KIT 6	CLIP, FUEL LINE Φ 8	1
88	KIT 9	SWITCH ASSEMBLY, OIL LEVEL	1
89		AMPLIFIER	1
90		BOLT M6X16	2
91	KIT 6	FUEL LINE RUBBER SLEEVE	1
92	KIT 6 or PH115177.E92	FUEL TANK FILTER	1
93	KIT 6 or PH115177.E93	FUEL OUTLET	1
94	KIT 5 or PH115177.E94	Recoil	1
95	KIT 5 or PH115177.E95	Engine Shroud	1

Engine Kit List

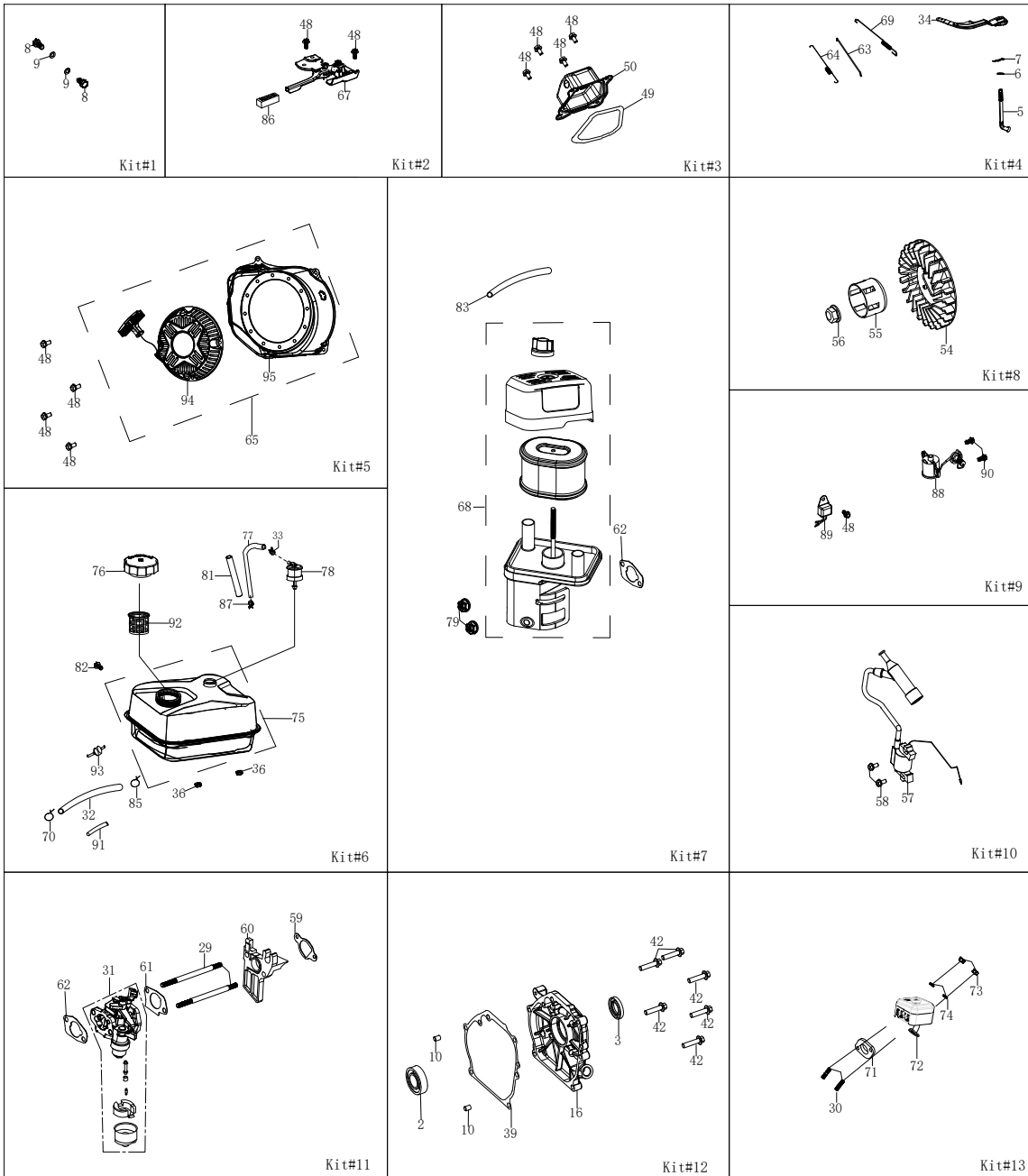

Kit ref #	Kit part#	Description	Qty
1	PH115177.EK1	Drain Bolt Kit	1
2	PH115177.EK2	Throttle Kit	1
3	PH115177.EK3	Valve Cover Kit	1
4	PH115177.EK4	Governor & Spring Kit	1
5	PH115177.EK5	Recoil Kit	1
6	PH115177.EK6	Tank Kit	1
7	PH115177.EK7	Air Cleaner Kit	1
8	PH115177.EK8	Recoil Starter Fan Kit	1
9	PH115177.EK9	Oil Level Kit	1
10	PH115177.EK10	Ignition Coil Kit	1
11	PH115177.EK11	Carburetor Kit	1
12	PH115177.EK12	Crankcase Cover Kit	1
13	PH115177.EK13	Muffler Kit	1

Engine Manual

⚠ WARNING

BEFORE operating the engine, be sure to read this section of the manual, otherwise injury to personnel or damage to equipment may occur.

Engine starting components

1. Fuel Valve
When the fuel valve is in the ON position, fuel is allowed to flow from the fuel tank to the carburetor. Be sure to return the fuel valve to the OFF position after stopping the engine.
2. Choke Lever
The choke is used to provide an enriched fuel mixture when starting a cold engine. It can be opened and closed by operating the choke lever manually. Move choke lever to the left toward CLOSED to enrich the mixture for cold starting.
3. Engine Switch
Turn the switch ON, (and pull recoil) to run the engine and to stop the engine turn the switch OFF.
4. Recoil
To start the engine, pull the starter rope lightly until resistance is felt, then pull briskly.
5. Throttle Lever
The throttle lever controls the engine speed. Pump Output is controlled by adjusting the throttle lever.

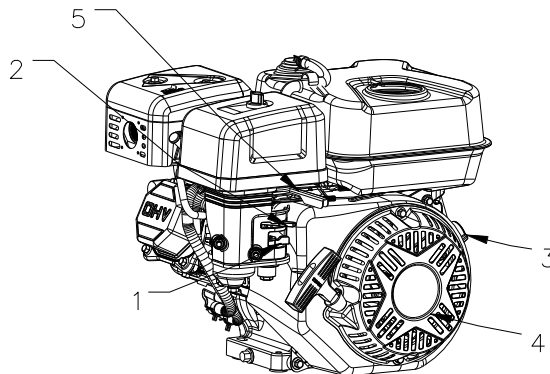

Displacement	212
Starting Type	Recoil/Electric Start
Ignition Type	Transistorized Magneto Ignition
Lubricating Type	Splash
Model	212cc
Spark Plug Gap	0.7-0.8mm (0.028-0.03in)
Spark Plug Torque	20-30N.m
Intake Valve Clearance	0.08-0.12mm (0.003-0.005in)
Exhaust Valve Clearance	0.13-0.17mm (0.005-0.007in)

⚠ WARNING:

Improper maintenance or failure to correct a problem before operation can cause a malfunction in which you can be seriously hurt or killed. ALWAYS follow the inspection and maintenance recommendations and schedules in this manual.

Maintenance schedule	REGULAR SERVICE PERIOD		Before each use	First month or 20 Hrs.	Every 3 months or 50 Hrs.	Every 6 months or 100 Hrs.	Every year or 300 Hrs.	
	Engine oil	Check level	○					
		Change		○		○		
	Air filter	Check	○					
		Clean			○(1)	○(1)		
		Replace						○
	Fuel Valve Sediment Cup	Clean				○		
	Spark plug	Check-adjust				○		
		Replace						○
	Spark arrester	Clean				○		
	Idle speed	Check-adjust					○(2)	
	Valve clearance	Check-adjust					○(2)	
	Cylinder head	Clean	After every 500Hrs. (2)					
	Fuel tank and filter	Clean	Every 2 years (Replace if necessary) (2)					
	Fuel tube	Check	Every 2 years (Replace if necessary) (2)					
<p>(1) Service more frequently when used in dusty areas.</p> <p>(2) These items should be serviced by an authorized generator service center, unless the owner has the proper tools and is mechanically proficient.</p>								
Engine oil recommendations	<p>⚠ CAUTION: Engine damage The pressure washer has been shipped WITHOUT oil. Any attempt to start pressure washer without oil may result in engine damage and failure.</p> <ul style="list-style-type: none"> • Engine oil is a key factor in deciding the engine's performance. DO NOT use engine oil with additives or 2-stroke gasoline oil, as they do not lubricate properly, which may shorten the engine's service life. • Check the engine oil level with the generator stopped on a level ground. • Due to viscosity variances with regions and temperatures select the correct type of oil using the chart below. <p>Engine oil recommended: SAE10W-30</p> <p>Capacity: 0.63 US quarts (0.6L)</p>							
<p>The chart shows ambient temperature in Fahrenheit (-20 to 100) and Celsius (-30 to 40). Three oil grades are indicated with arrows: 5W-30 (left arrow, below 0°F), 10W-30 (middle arrow, between 0°F and 40°F), and 30 (right arrow, above 40°F).</p>								

Oil draining and checking oil level

⚠ WARNING: Burn hazard

Never open oil port while engine is running. Hot oil can spray over face and body.

1. Operate the pressure washer for 3 to 5 minutes to thin oil for easier draining.
2. Ensure that the engine is stopped and on a level surface.
3. Remove the drain bolt and washer; drain the oil into an approved container.

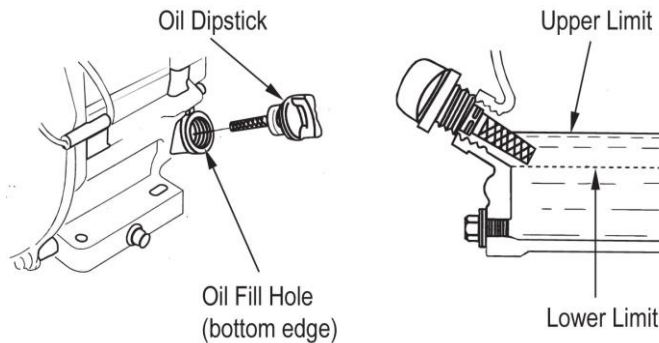

4. Reinstall washer and drain bolt.
5. Remove the dipstick and clean it.
6. Fill crankcase with oil to the bottom lip of the oil filler neck, approximately 0.63 US quarts (0.6L).
7. Reinsert the dipstick into the oil filler without threading in, and check oil level. If the oil level is too low, add recommended engine oil to the oil filler neck.
8. Reinstall the dipstick.

Spark plug removal, cleaning and replacement

Proper spark plug clearance ensures the engine's normal running.

- a) Remove the spark plug cap.
- b) Remove the spark plug using a spark plug wrench.

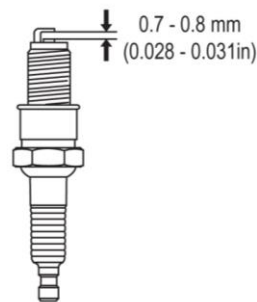
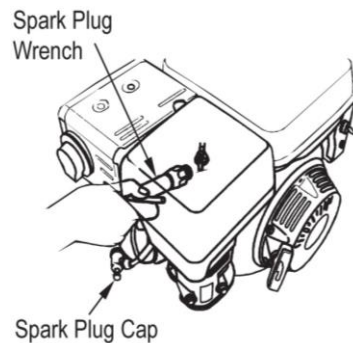

⚠ WARNING

Be careful not to touch the muffler during or just after the engine has been running.

- c) Clean the spark plug with a steel brush. If the insulator is damaged, replace the spark plug.
- d) Measure the spark plug clearance with a feeler. The clearance should be 0.7-0.8mm. If adjustment is necessary, bend the side electrode carefully.
- e) Check if the spark plug gasket is in good conditions, or replace with a new one. Screw on the spark plug to the bottom first by hand and then tighten it up by using spark plug wrench. If a new spark plug is used, twist 1/2 more turns after impacting the gasket; if reinstall the original one, just twist 1/8-1/4 more turns.

Clean air filter

⚠ WARNING

Never run the pressure washer without the air filter. Rapid engine wear will result.

1. Remove the air cleaner outside cover (A). Be careful to prevent dirt and debris from falling into the air cleaner assembly.
2. Separate the Air Filter (A) from the Air Filter Housing (B).
3. Inspect the air filter. Clean dirty air filter with warm water and mild soap. Allow air filter to dry thoroughly before re-installation.
4. Install the air filter assembly onto the carburetor and secure with screws.

Note: Do not use pressurized air or solvents to clean the filter. Pressurized air can damage the filter and solvents will dissolve the filter.

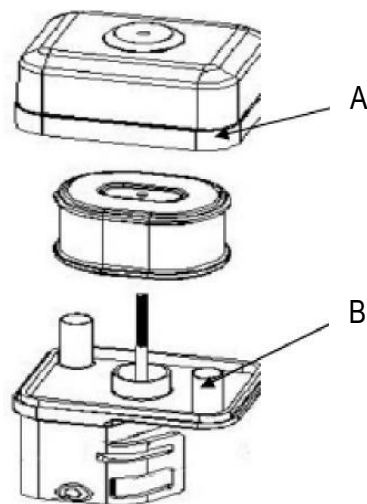

Prepare engine for long term storage if needed

If you will not be able to exercise the pressure washer regularly, you must prepare the engine for long term storage to prevent gum deposits from forming and causing malfunction of the engine.

Prepare engine for long term storage by:

Removing all gasoline from the tank and carburetor.

Draining steps:

1. Position a UL-listed fuel container below the carburetor drain bolt.
2. Turn fuel valve to the OFF position.
3. Remove the drain bolt and gasket.
4. Turn fuel valve to the ON position and drain fuel from carburetor and tank.
5. Reinstall and tighten the drain bolt and gasket.

OR

Adding fuel stabilizer to the gasoline (following manufacturer's instructions).

Fuel stabilizer steps:

1. Ensure gasoline tank is full.
2. Add fuel stabilizer to fuel tank.
3. Run engine at least 10 minutes after adding stabilizer to allow it to enter the fuel system.
4. Shut off engine.
5. Disconnect spark plug wire and remove spark plug using a spark plug wrench.
6. Add one teaspoon oil through spark plug hole.
7. Place rag over spark plug hole and turn starter (or pull the recoil) a few times to lubricate the combustion chamber.
8. Replace spark plug, but do NOT reconnect the spark plug wire.

Removal from storage	<p>⚠ WARNING Gasoline is highly flammable and explosive, and you can be burned or seriously injured when handling fuel.</p> <table border="1" data-bbox="412 296 1438 573"> <thead> <tr> <th data-bbox="412 296 732 331">Storage time</th> <th data-bbox="732 296 1438 331">Service item</th> </tr> </thead> <tbody> <tr> <td data-bbox="412 331 732 367">Within one month</td> <td data-bbox="732 331 1438 367">Use</td> </tr> <tr> <td data-bbox="412 367 732 403">One-two months</td> <td data-bbox="732 367 1438 403">Drain original fuel and refuel.</td> </tr> <tr> <td data-bbox="412 403 732 472">Two months - one year</td> <td data-bbox="732 403 1438 472">Drain original fuel and refuel; Empty and clean the fuel valve sediment cup.</td> </tr> <tr> <td data-bbox="412 472 732 573">One year or longer</td> <td data-bbox="732 472 1438 573">Drain original fuel and refuel; Empty and clean the fuel valve sediment cup; Empty and clean the carburetor bowl.</td> </tr> </tbody> </table> <p>Draining fuel:</p> <ol style="list-style-type: none"> 1. Turn the fuel valve to the OFF position. 2. Place a UL-listed container below the carburetor; use a funnel to avoid spillage. 3. Remove the carburetor drain bolt and gasket. 4. Turn the fuel valve to the ON position to drain fuel into a UL-listed container. 5. Reinstall and tighten the drain bolt and gasket. 	Storage time	Service item	Within one month	Use	One-two months	Drain original fuel and refuel.	Two months - one year	Drain original fuel and refuel; Empty and clean the fuel valve sediment cup.	One year or longer	Drain original fuel and refuel; Empty and clean the fuel valve sediment cup; Empty and clean the carburetor bowl.
Storage time	Service item										
Within one month	Use										
One-two months	Drain original fuel and refuel.										
Two months - one year	Drain original fuel and refuel; Empty and clean the fuel valve sediment cup.										
One year or longer	Drain original fuel and refuel; Empty and clean the fuel valve sediment cup; Empty and clean the carburetor bowl.										
High Altitude Operation	<p>CAUTION: Operating at an altitude of greater than 2000 feet (610 meters) may affect your engines performance, fuel consumption, and emissions. To remain emissions compliant and improve engine performance at higher altitudes, a high-altitude kit is required. A high altitude kit includes a carburetor jet resized to help correct air / fuel mixture at altitude. To order a high altitude kit or if you have additional questions, go to www.northerntool.com or contact us at 1-866-443-2576 – Powerhorse. Please note, engines with the high-altitude kit installed operated at lower altitudes could cause severe engine damage and affect emissions compliance. When modified, a tag or decal should be added to the product stating that a high-altitude kit was installed and to remind you to re-service the carburetor (re-jet) when operating in lower altitude environments.</p>										

Limited Warranty

Dear Valued Customer:

The Powerhorse Product you just purchased is built with the finest material and craftsmanship. Use this product properly and enjoy the benefits from its high performance. By purchasing a Powerhorse product, you show a desire for quality and durability. Like all mechanical equipment this unit requires a due amount of care. Treat this unit like the high-quality piece of machinery it is. Neglect and improper handling may impair its performance. Please thoroughly read the instructions and understand the operation before using your product. Always contact Powerhorse Product Support at 1-866-443-2576 prior to having any service or warranty work performed, as some services performed by parties other than Powerhorse approved service centers may void this warranty. This warranty is in lieu of any other warranty expressed or implied and Powerhorse assumes no other responsibility or liability outside that expressed within this warranty.

Limited Warranty

Powerhorse shall warranty any piece of equipment manufactured, or parts of equipment manufactured, to be free from defects in material or workmanship for a period of:

Powerhorse Warranty		
Item #	Consumer Warranty Period	Commercial Warranty Period
115177	2 years from date of purchase by user	90 days from date of purchase by user

“Consumer use” means personal residential household use by a consumer. “Commercial use” means all other uses, including use for commercial, income producing or rental purposes or when purchased by a business.

This warranty applies to the original purchaser of the equipment (verification of purchase, in the form of a receipt, is the responsibility of the buyer), is non-transferable, and covers parts and labor. Parts will be replaced or repaired at no charge, except when the equipment has failed due to lack of proper maintenance. If a part is no longer available, the part may be replaced with a similar part of equal function. Any misuse, abuse, alteration or improper installation or operations will void warranty. Determining whether a part is to be replaced or repaired is the sole decision of Powerhorse. Powerhorse will not provide for replacement of complete products due to defective parts. Any costs incurred due to replacement or repair of items outside of a Powerhorse approved facility is the responsibility of the buyer and not covered under warranty. Transportation costs to and from service center is the responsibility of the customer.

In addition to the normal warranty, Powerhorse shall warrant any normal wear item from defects in material or workmanship for a period of 90 days from the date of purchase by user. Normal wear items include, but are not limited to, nozzles, quick connect fittings, valves, seals, hoses, springs, O-rings, unloader valves and filter elements.

This warranty specifically excludes the following: failure of parts due to damage caused by accident, fire, flood, windstorm, acts of God, applications not approved by Powerhorse in writing, corrosion caused by chemicals, use of replacement parts which do not conform to manufacturer’s specifications, damage related to rodent and/or insect infestation and damage caused by vandalism. Additional exclusions: loss of running time, inconvenience, loss of income, or loss of use, including any implied warranty of merchantability of fitness for a specific use. Also, Outdoor Power Equipment needs periodic parts and service to perform well, and this warranty does not cover instances when normal use has exhausted the life of a component or the engine.

This warranty does not cover any personal injury or damage to surrounding property caused by failure of any part. Repair or replacement of parts does not extend the warranty period.

The engine warranty is covered under the same terms and conditions as outlined above. Normal engine maintenance such as spark plugs, air filters, adjustments, fuel system cleaning and obstruction due to build up is not covered by this Powerhorse warranty.

Tel: 1-866-443-2576

Website: www.northerntool.com

Please fill in the following information and have it on hand when you call in on a warranty claim.

Customer Number: _____

Date of Purchase: _____

Powerhorse Serial Number: _____

Item Number: _____

This page left intentionally blank

POWER HORSE™

Distributed by:
Northern Tool & Equipment Company, Inc.
Burnsville, MN 55306
www.northerntool.com
Assembled in the U.S.A
of foreign components